

Page

- History and Growth of Chlorine2
- Production Process3
- Characteristics.....4
- Chlorine Containers.....4
 - Cylinders5
 - Ton Containers.....8
 - Tank Cars11
 - Cargo Tank Trucks14
- Handling Equipment.....15
- Safety and Emergency Information.....17
- Technical Data.....20

Foreword

This handbook outlines the methods for handling, storing, and using chlorine. It also includes information on the manufacture and physical properties of chlorine.

Additional information and contacts can be found on the internet at www.oxychem.com

Occidental Chemical Corporation
 Basic Chemicals Group
 Occidental Tower
 5005 LBJ Freeway
 Dallas, Texas 75244

THE INFORMATION PRESENTED HEREIN WAS PREPARED BY TECHNICAL PERSONNEL AND IS TRUE AND ACCURATE TO THE BEST OF OUR KNOWLEDGE. **OXYCHEM DOES NOT MAKE ANY WARRANTY OF MERCHANTABILITY OR FITNESS FOR A PARTICULAR PURPOSE, EXPRESS OR IMPLIED, REGARDING PERFORMANCE, STABILITY OR ANY OTHER CHARACTERISTIC.** THE INFORMATION CONTAINED HEREIN IS NOT TO BE CONSTRUED AS AN EXPRESS WARRANTY CONCERNING THE PERFORMANCE, STABILITY OR ANY OTHER CHARACTERISTIC OF ANY OXY-CHEM PRODUCT. THIS INFORMATION IS NOT INTENDED TO BE ALL-INCLUSIVE AS TO MANNER OR CONDITIONS OF USE. HANDLING, STORAGE, DISPOSAL AND OTHER ACTIVITIES MAY INVOLVE OTHER OR ADDITIONAL LEGAL, SAFETY OR PERFORMANCE CONSIDERATIONS. WHILE OUR TECHNICAL PERSONNEL WILL RESPOND TO ANY QUESTIONS REGARDING SAFE HANDLING AND USE PROCEDURES, SAFE HANDLING AND USE REMAINS THE RESPONSIBILITY OF THE CUSTOMER. NO SUGGESTIONS FOR USE ARE INTENDED AS, AND NOTHING HEREIN SHALL BE CONSTRUED AS A RECOMMENDATION TO INFRINGE ANY EXISTING PATENT OR TO VIOLATE ANY FEDERAL, STATE OR LOCAL LAW.

History and Growth of Chlorine

The earliest annals of chemistry mention chlorine compounds. In 77 A.D., Pliny the Elder published one of the first practical collections of chemical reactions. His formula for gold purification generated chlorine as a by-product in the form of hydrogen chloride. But more than 800 years passed before written records showed that the Arabs had learned to react chlorine with water to produce hydrochloric acid.

Around 1200 A. D., alchemists discovered that a mixture of hydrochloric and nitric acids dissolved gold. This procedure generates chlorine, but there is no record that a heavy greenish gas was evolved. In 1630, Belgian Jean Baptiste van Helmont wrote of a "salt gas" that we know contained chlorine, but it wasn't until 1774 that Swedish apothecary, Carl Wilhelm Scheele, generated, collected, and studied chlorine as an end in itself.

Even Scheele's discovery was nearly accidental. He collected chlorine out of simple curiosity. Perhaps he too would have treated the gas casually if he hadn't, on some impulse, placed some leaves and flowers into a bottle of chlorine. Within minutes the plants had turned white, and man had the first historical record of the bleaching action of chlorine.

Scheele's discovery came when both modern chemistry and the industrial revolution were taking their first halting steps down paths that would soon change the course of history. Antoine Lavoisier, the father of modern chemistry, took note of Scheele's work and quickly became embroiled in a controversy over whether chlorine was an element or a compound. Meanwhile, textile producers in the French town of Javelle heard of the bleaching action of this gas, and in 1789 bubbled it through a potash solution producing *eau de Javelle*, *Javelle Water*, the first commercial liquid chlorine bleach.

The eruption of the French Revolution cut short the intellectual ferment begun by Lavoisier and his followers. Lavoisier himself was guillotined in 1793, but his chemistry had crossed the English Channel. Once again, scientific curiosity paralleled commercial necessity. Humphry Davy, the English father of electrolysis, demonstrated that chlorine was an element with properties useful to Britain's rapidly expanding textile and paper industries.

In the 1830's Michael Faraday, Davy's lab assistant, produced a definitive work on both the electrolytic generation of chlorine and the ease of its liquefaction. In 1851, Charles Watt obtained the first English patent for an electrolytic chlorine production cell.

Through the 1880's and 1890's producers in Germany, England, Canada, and the United States refined chlorine technology. Around 1890, German producers learned that, while wet liquid chlorine was almost impossible to package, removal of all water allowed safe shipment in ordinary iron or steel pressure vessels.

By the early 1900's, chlorine was produced in mercury and diaphragm electrolytic cells and shipped in liquid form as a matter of course. A modern chlorine industry had formed. By 1913, the first permanent liquid chlorine water purification system had been installed in Philadelphia. The following year, Altoona, Pennsylvania, became the first city to treat sewage with liquid chlorine.

World War I brought added impetus to North American chlorine production. Submarine warfare practically eliminated imports of chemicals from Europe at a time when markets for many chemicals, including chlorine, were growing rapidly. By the end of the war, the United States had a large and firmly entrenched domestic chlorine industry.

In the 1930's, the world's chemical industry erupted in a period of extraordinary growth that still continues. Bleaching properties of chlorine became just one of its major uses. Its disinfecting properties remained vital to health, but became a minor market for a chemical that would soon affect almost every human activity.

Today, we use chlorine as a raw material in the manufacture of polyvinyl chloride, a plastic used in fabricating flooring, pipe, wallpaper, clothing, furniture, and a wide range of household products. . We treat our illnesses with complex drugs and spray our crops with insecticides, herbicides, and fungicides which contain chlorine as part of their basic structure. Chlorinated chemicals also enable us to refrigerate and freeze our food, cool our homes, offices and cars, and even insulate our buildings from the heat and cold.

One of the most important uses of chlorine is helping produce chemicals that contain no chlorine at all. Chlorine and chlorine chemicals help promote reactions that produce chemicals for antifreeze, textile lubricants, fabric softeners, book-binding pastes, solvents for lacquers, brake fluids, polyester fibers, and a host of other products.

Production Process

The basic raw material for the process, salt, comes from either mines or underground wells. Mined salt is dissolved with water to form raw brine. In other cases, water is pumped into salt deposits, forming brine in the earth that is tapped and drawn off from the resulting brine well.

Raw brine contains impurities that interfere with chlorine-caustic production. They are removed by chemical treatment, settling, and filtration. The purified brine is pumped to the cell room. The cell room contains one of three types of electrolytic cells for decomposing

brine into chlorine, caustic soda, and hydrogen. These three cell types are diaphragm, membrane, or mercury cells.

The chlorine that leaves the cell is hot and wet, and therefore very corrosive. It must be cooled and dried before it can be processed in ordinary steel equipment. In addition, the chlorine stream is contaminated with air, hydrogen, and some carbon dioxide (due to small amounts of carbon bearing chemicals in the brine).

Once the chlorine stream is cooled and dried, compressors and refrigeration machines are used to liquefy the gas. Chlorine is most easily handled as a liquid in specially designed pressure containers.

Any gaseous contaminants in the chlorine stream are removed. Small amounts of chlorine mixed with them are nearly completely recovered. The recovered chlorine is then returned to the liquefaction process.

Chlorine Process

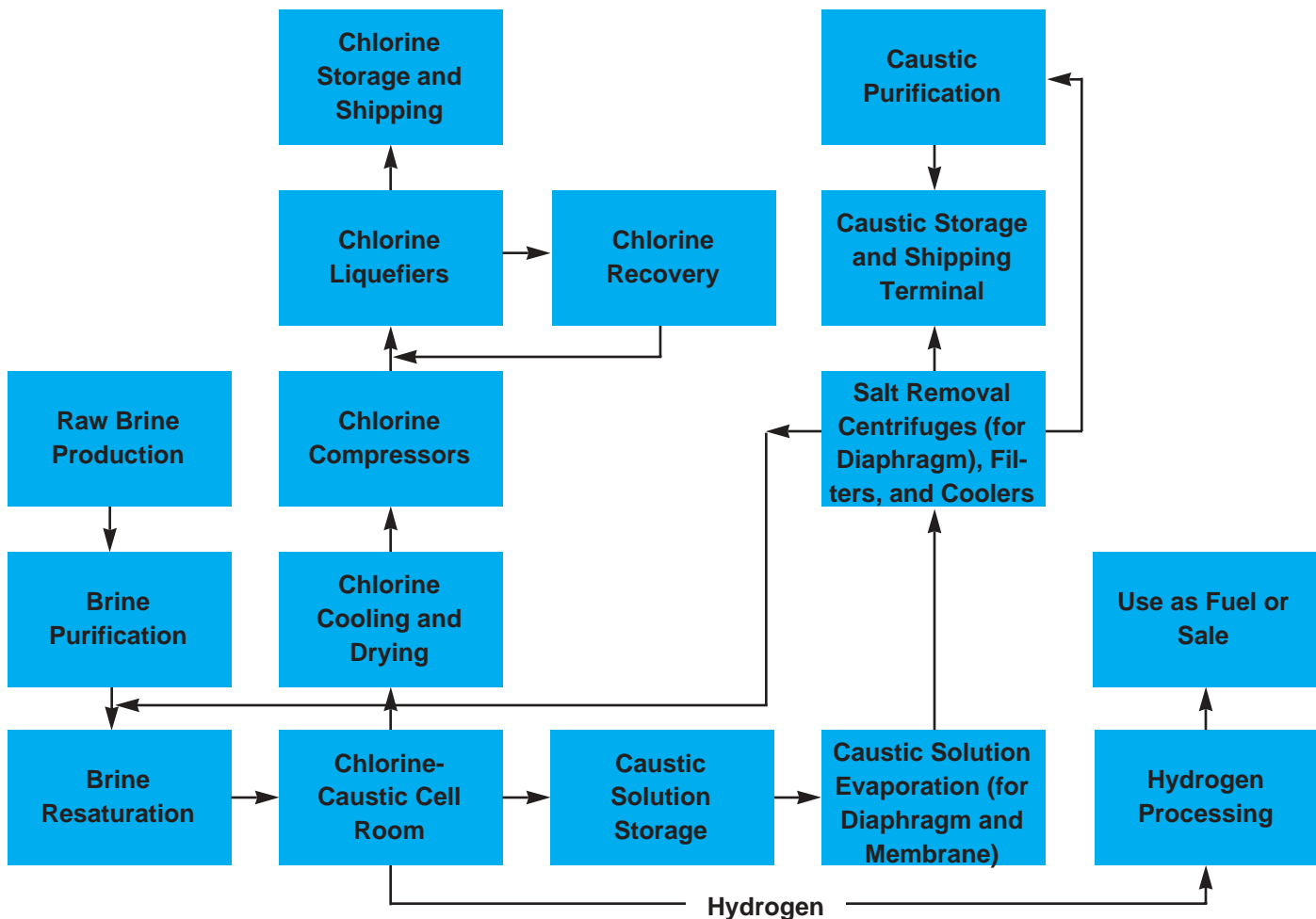

Characteristics

Chlorine, at ordinary conditions of temperature and pressure, is a greenish-yellow gas with a pungent and irritating odor. Since chlorine is very active chemically, it is found in nature only in combination with other elements. Sodium chloride, for example, is widely and abundantly distributed in nature and constitutes the chief source of chlorine. Because gaseous chlorine is approximately two-and-one-half times as heavy as air, it is slow to diffuse into the air. It tends to accumulate in low places.

Gaseous chlorine can be liquefied by the application of pressure at reduced temperatures to form a clear, amber-colored liquid. Liquid chlorine is approximately one-and-one-half times as heavy as water.

In the presence of moisture, both gaseous and liquid chlorine are extremely corrosive to common metals of construction. At low pressures, wet chlorine can be handled in equipment made of glass, chemical stoneware, titanium, and certain plastics. Installations employing wet

chlorine require special care and recommendations can be made only after a thorough and careful investigation. Platinum, tantalum, and titanium are some of the metals resistant to moist chlorine.

Dry chlorine, both gaseous and liquid, can be handled safely in equipment fabricated from iron, steel, certain stainless steels, Monel metal, nickel, copper, brass, bronze, and lead. These metals are not aggressively attacked by dry chlorine but the slightest trace of moisture will cause severe corrosion. However, dry chlorine attacks metals at elevated temperatures. Chlorine reacts with carbon steel at elevated temperatures. Operations above 250°F should be avoided.

Since chlorine boils at about -30°F, under certain conditions it can embrittle ordinary carbon steels. If temperatures below -20°F are expected to occur, special carbon steels, or other materials of construction should be considered.

Chlorine is an excellent oxidizing agent which accounts for its widespread use as a bleaching agent. Liquid and gaseous chlorine are nonflammable and will not support combustion in the normal sense. However, chlorine will support the combustion of certain materials under special conditions.

Dry chlorine has an extremely high affinity for moisture. Regardless of the environmental conditions of temperature and humidity, all open ends of chlorine pipelines should be sealed with rubber stoppers or some type of moisture-tight closure when not in use. An open end of a chlorine delivery line will, within a time interval of only a few minutes, pick up sufficient moisture from the atmosphere to cause severe corrosion.

Chlorine Containers

Chlorine is supplied in packages of varying sizes according to the requirements of the customer. Cylinders with a 100 or 150 pound capacity are available to customers needing small quantities. Ton containers (2000 lbs. net) can be supplied to consumers requiring intermediate tonnage. Containers of these sizes are supplied by independent distributors (Repackagers) and not by OxyChem.

Additionally, chlorine cargo tank trucks with a 15 to 20 ton capacity are in limited use and only available from certain Repackagers.

Receipt of chlorine by tank car requires special handling and compliance with the Department of Transportation (DOT) Hazardous Materials Regulations, CFR Title 49. Tank cars are supplied by OxyChem and are available in 90 ton capacities. 55 ton tank cars are in

limited use and will be phased out of service after 2002.

All chlorine containers and fittings are of a type approved by The Chlorine Institute, Inc. and must comply with the specifications and regulations of the DOT. Most Repackagers maintain facilities for the inspection, cleaning, testing, and filling of these containers.

Cylinders

Liquid chlorine cylinders are seamless steel construction. Cross-sectional drawings of 100-pound and 150-pound cylinders are shown in Figure 1. Cylinders are fitted with valves in compliance with the specifications and regulations of the DOT and approved by The Chlorine Institute, Inc. The U.S. DOT (or Canadian equivalent) specification number, serial number, identifying symbol, original tare weight, inspector's official mark, and date of hydrostatic is stamped on the metal

near the cylinder neck. Usually the owner's name or symbol is stamped or embossed in the same area. To mar or deface these markings is illegal.

Each cylinder is fitted with a cap to protect the valve mechanism. It must be kept in place whenever the cylinder is not in actual service. A cross-sectional drawing of a chlorine cylinder valve is shown in Figure 2.

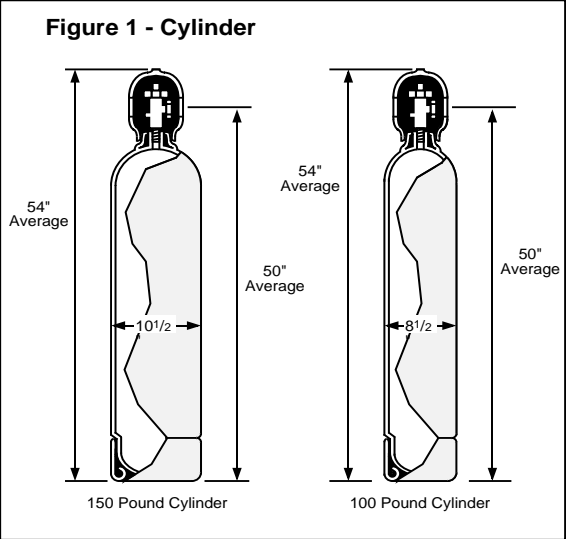

Dimensions of Cylinders

Capacity lbs	Tare Weight lbs	Total Height inches	Outside Diameter inches
100	63 -115	39.5 - 59"	8.25 - 0.75"
150	85 -140	53.0 - 56"	10.25 - 10.75"

The outlet threads of a chlorine cylinder valve are not standard pipe threads. For this reason, a special clamp and adapter, as shown in Figure 3, is suggested. The use of the clamp and adapter affords greater convenience for the consumer and protects the cylinder valve from excessive wear.

The chlorine cylinder valve is equipped with a fusible metal plug which is a safety device designed to melt at about 158°F. This safety plug protects the chlorine cylinder against excessive pressure, by melting and allowing the contents of the cylinder to escape when

exposed to high temperature. The fusible metal plug is located below the valve seat and cannot be controlled by the valve. The fusible metal plug should not be tampered with under any circumstances.

No wrench other than the one shown in Figure 3 should be used to open or close chlorine cylinder valves. Use of another wrench may damage the valve stem and make the valve difficult to close.

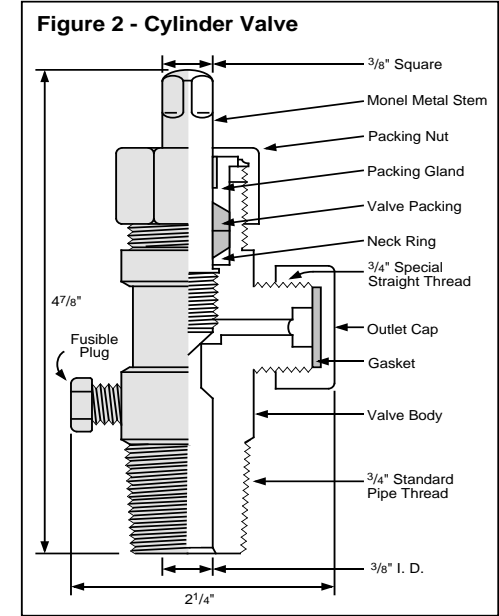

Storage of Cylinders

Figure 3 - Valve Adapter and Clamp

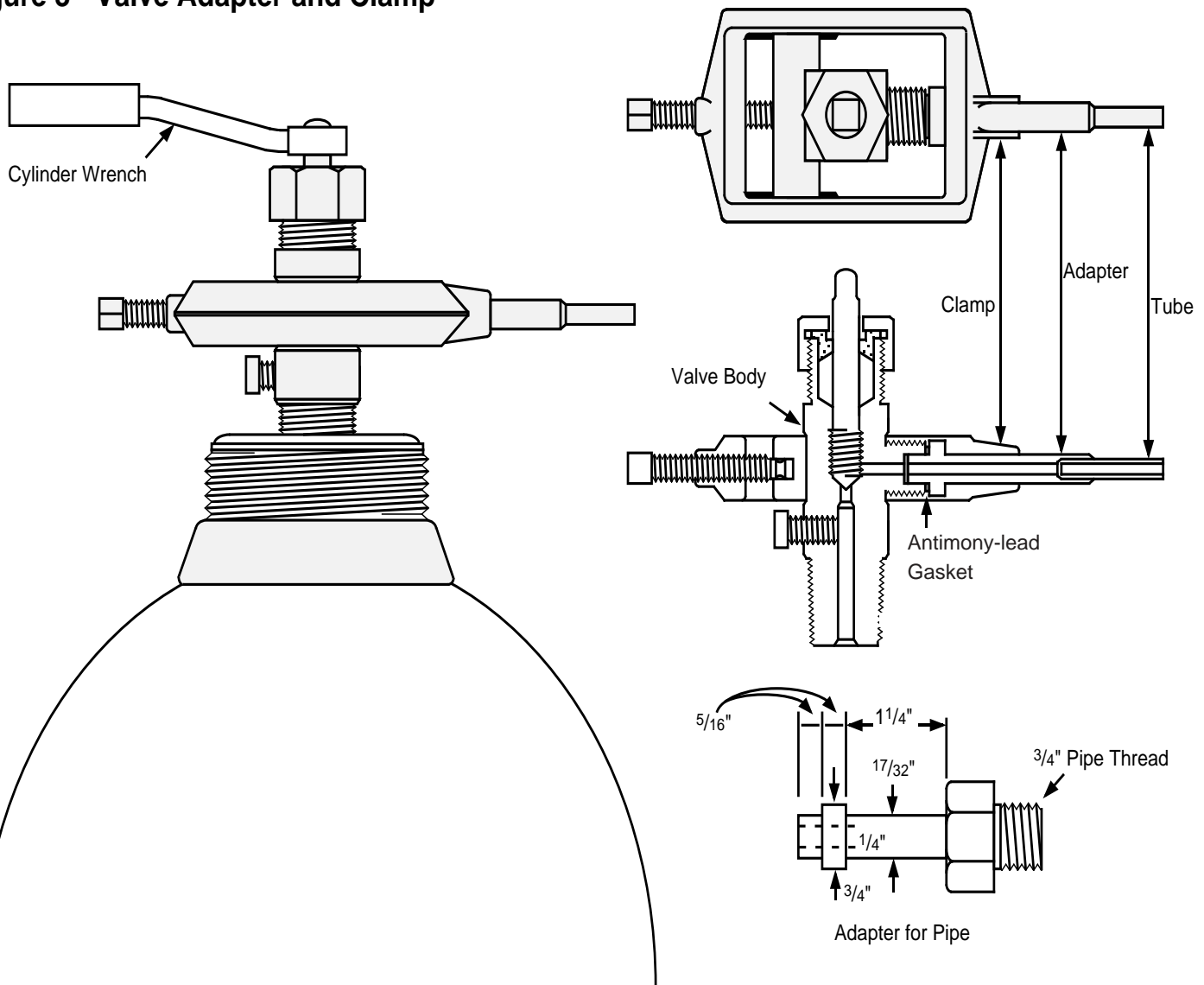

Store cylinders of liquid chlorine in a cool place away from steam pipes or other sources of heat.

Store cylinders, full or empty, with their valve outlet caps and valve protective caps in place.

Store all cylinders of liquid chlorine in a location which is protected from direct sunlight and from dampness.

Do not store cylinders where it is possible for leaking vapors to enter a ventilating system.

Store all cylinders in a vertical position.

Store cylinders so that the oldest shipments of cylinders are used

first. Valve packing may harden with prolonged storage, causing leaks when the cylinders are used.

Storage areas should be kept clean so that accumulated trash does not present a fire hazard.

Handling and Use of Cylinders

It is illegal to ship a leaking chlorine cylinder or a chlorine containing cylinder which has been exposed to fire. Consult your chlorine supplier for advice under such circumstances.

If a chlorine cylinder or its valve is found out of order, notify the distributor from whom the chlorine was purchased, giving the cylinder number and the nature of the damage.

Handle all chlorine cylinders with extreme care. Do not drop cylinders or allow them to strike any object with force. Do not apply heat to chlorine cylinders or their valves.

Operate chlorine cylinder valves only with the wrenches shown in Figure 3. Under no circumstances use a pipe wrench or any wrench longer than six inches. Always use the correct special clamps and adapters as shown in Figure 3.

Use valves, gauges, regulators, and fittings which have been approved for chlorine service. Ordinary devices are not suitable.

The cylinder must be in an upright position to remove chlorine as a gas. If liquid chlorine is to be withdrawn from a cylinder, the cylinder

must be inverted and clamped securely on a rack set at an angle of about 60° to the horizontal.

Use flexible connections between cylinders and piping systems (Figure 4). Copper tubing capable of withstanding pressures up to 400 pounds per square inch is satisfactory for dry chlorine.

Close valves on chlorine cylinders when chlorine is not being withdrawn in order to prevent moist air or foreign substances from entering the cylinder. It is dangerous to allow any chlorine cylinder, which has emptied its contents into water or another liquid, to remain connected with the process line. In such cases liquid could be sucked back into the cylinder causing danger to the operator and damage to the cylinder.

Replace outlet cap and valve protective cap as soon as the cylinder is disconnected.

Do not alter or repair chlorine cylinders or their valves.

Leaks around the valve stem are usually corrected by tightening the packing nut in a clockwise direction. All threads on all chlorine valves are right-hand threads.

Provide suitable hand trucks for moving cylinders. These should be properly balanced and have a clamp support at least two-thirds of the way up the cylinder. If chlorine cylinders are to be lifted, provide a suitable sling. Do not use a chain, rope, or magnetic device. Do not lift cylinders by their valve protective caps because they are not designed for this purpose.

To monitor the consumption of chlorine at any given time, place the cylinder on a scale. The difference in weight between measurements will equal the quantity consumed.

Figure 4 - Flexible Tubing Connector for Ton Containers and Cylinders

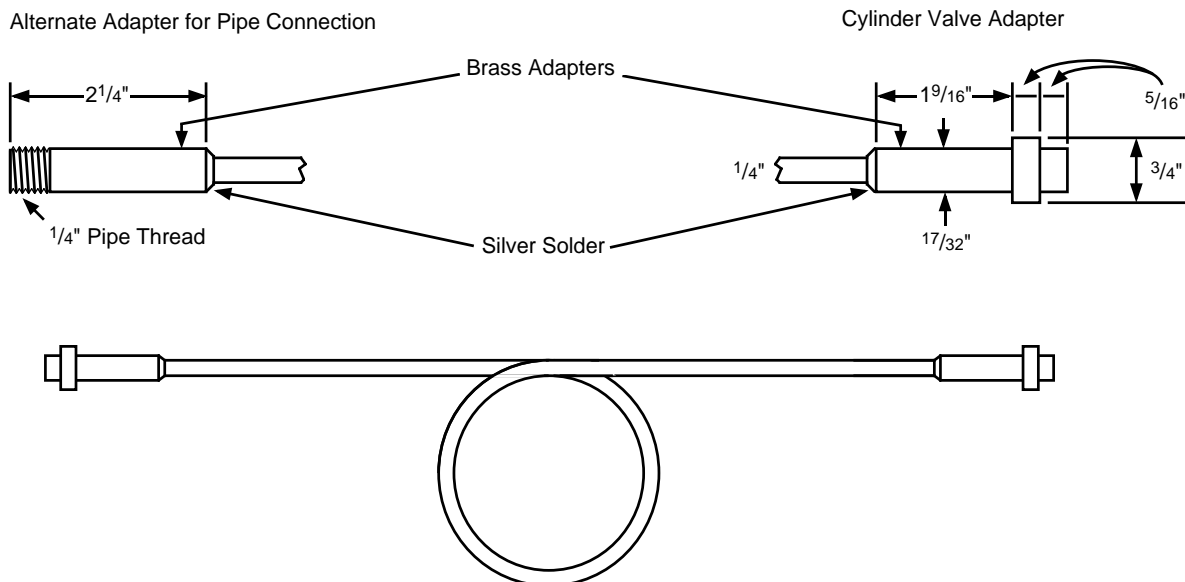

Ton Containers

The ton containers for liquid chlorine are constructed of steel. Like the cylinders, they are fitted with valves approved by The Chlorine Institute, Inc. and in compliance with the specifications and regulations of the DOT.

The average ton container (Figure 5) is about 30 inches in outside diameter and about 82 inches in length. Average tare weight is about 1500 pounds, average gross weight is about 3500 pounds, leaving 2000 pounds net weight.

Each end of a ton container is concave. The sides are crimped inward over the ends to form chimes that provide suitable grips for hooks used in handling. Each container is equipped with two valves, both of which are located at the same end, near the center. The valves are connected to education pipes as shown in Figure 5. With the container placed horizontally so that the two valves are in vertical alignment, the lower valve will deliver liquid chlorine. Gaseous chlorine from above the liquid level will flow through the upper valve. Pointed

arrows on the valve end of a ton container indicate the position of the two valves. These arrows are visible when the protective bonnet is in place, allowing proper positioning of a ton container before removing the bonnet. There are six fusible metal plugs in each ton container, three on each end. The fusible metal in these plugs melts at about 158°F. The melting plug prevents build up of excessive pressure when exposed to high temperature. The fusible metal plugs should not be tampered with under any circumstances. The container number, dates of hydrostatic tests, and water capacity are stamped in the metal of an unpainted portion of the chime at the valve end of each ton container. To mar or deface these markings is illegal. The tare weight of each ton container is stenciled on the end opposite the valves.

The ton container valve is the same as the cylinder valve except that it has a larger discharge port and no fusible metal plug. A cross section of the ton container valve is shown in Figure 6. The outlet threads of a ton container valve are not standard pipe threads. For that reason, a special clamp and adapter shown in Figure 3, are suggested.

The use of the clamp and adapter affords greater convenience for the consumer and protects the ton container valve from excessive wear.

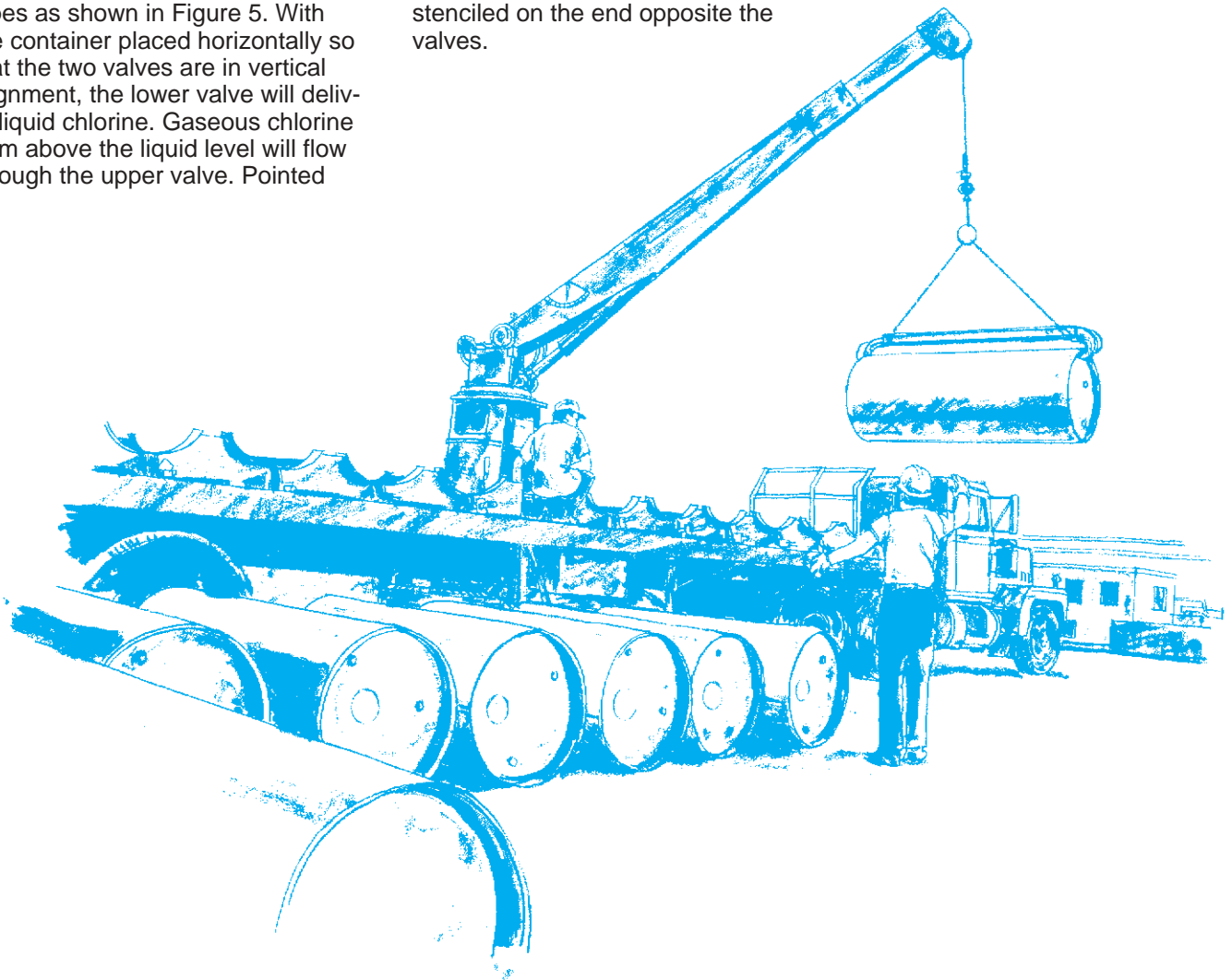

Storage of Ton Containers

Only the wrench shown in Figure 3 is to be used to open or close a ton container valve. Clamps, adapters, and valve wrenches are available from your chlorine distributor.

A suitable hoist equipped with a lifting beam as shown in Figure 7 is required to remove or replace the containers.

Storage

Store ton containers of liquid chlorine in a cool place, away from steam pipes or other sources of heat.

Store all ton containers, full or empty, with their valve outlet caps and valve protective bonnets in place.

Store all ton containers of liquid chlorine in a location which is protected from direct sunlight and from dampness.

Do not store ton containers of liquid chlorine near flammable materials.

Store ton containers where it is not possible for leaking vapors to enter a ventilating system.

Store ton containers in a horizontal position on a level rack. Keep them on the same level. Do not stack ton cylinders to avoid the possibility of the one at the bottom developing a leak and being difficult to remove.

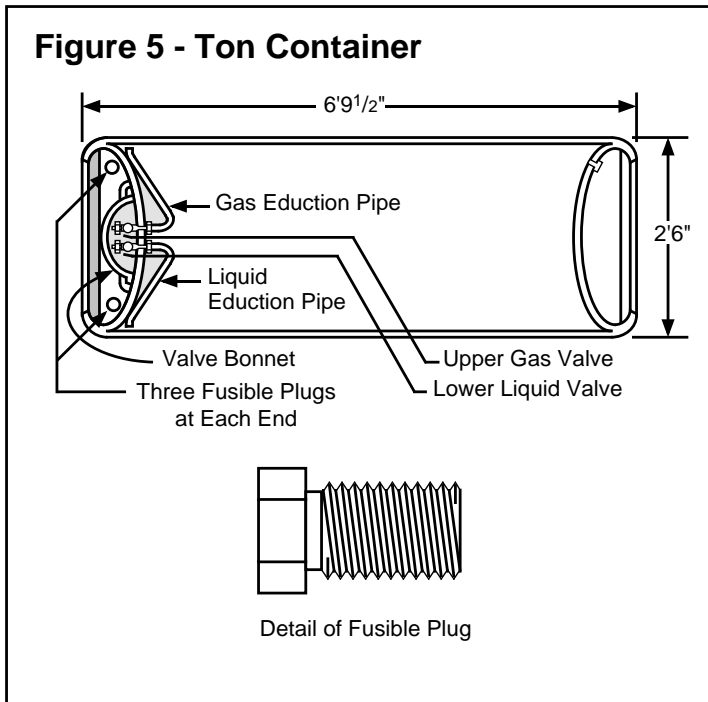
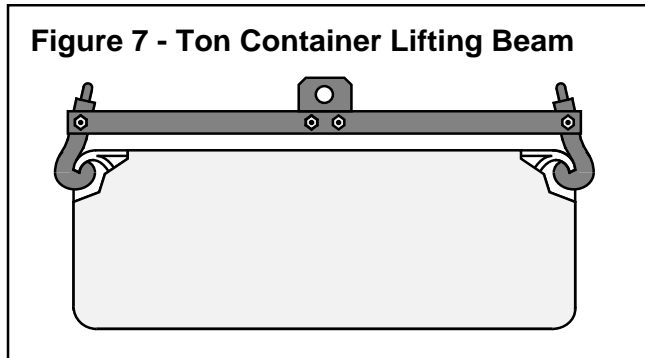
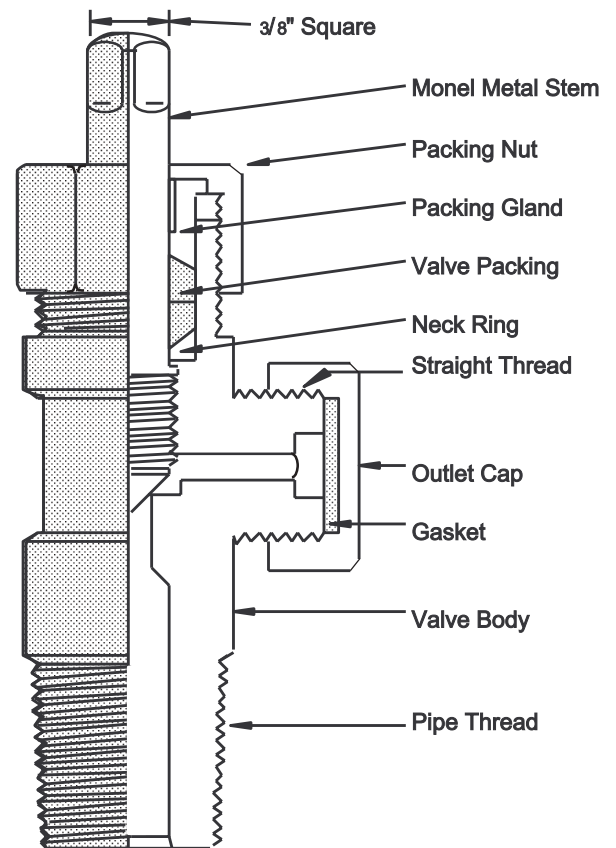

Figure 6 - Ton Container Valve



Handling and Use of Ton Containers

Shipping a leaking chlorine container or one, partially or fully loaded, which has been exposed to fire is illegal. Consult your distributor for advice under such circumstances.

If a ton container or its valves are found out of order, notify the distributor from whom the chlorine was purchased, giving the container number and nature of the damage.

Handle all chlorine ton containers with extreme care. Do not drop ton containers or allow them to strike any object with force. Do not apply heat to ton containers or their valves.

Ton container valves should be operated only with wrenches as shown in Figure 3. Under no circumstances use a pipe wrench or any wrench longer than six inches. Always use special clamps and adapters. (See Figure 3.)

Use valves, gauges, regulators, and fittings which have been approved for chlorine service. Ordinary devices are not suitable.

Use flexible connections between ton containers and piping systems. (See Figure 4.) Copper tubing capable of withstanding pressures of 400 pounds per square inch is satisfactory for dry chlorine. A typical installation is shown in Figure 8.

Use the lower valve to withdraw liquid chlorine and the upper valve to remove chlorine gas.

Close valves on ton containers when chlorine is not being withdrawn to prevent moist air or foreign substances from entering the container. It is dangerous to allow any chlorine container, which has emptied its contents into water or other liquid, to remain connected with the process line. In such cases, liquid could be sucked back into the container causing danger to the operator and damage to the container.

Replace outlet caps and valve protective bonnets as soon as the containers are disconnected.

Always have an attendant present when chlorine is being withdrawn from a ton container.

Do not alter or repair ton containers or their valves.

Leaks around the valve stem usually can be corrected by tightening the packing nut in a clockwise direction. All threads on all chlorine valves are right-hand threads.

Place a ton container on a scale as its contents are removed to determine the quantity of chlorine in the container at any time.

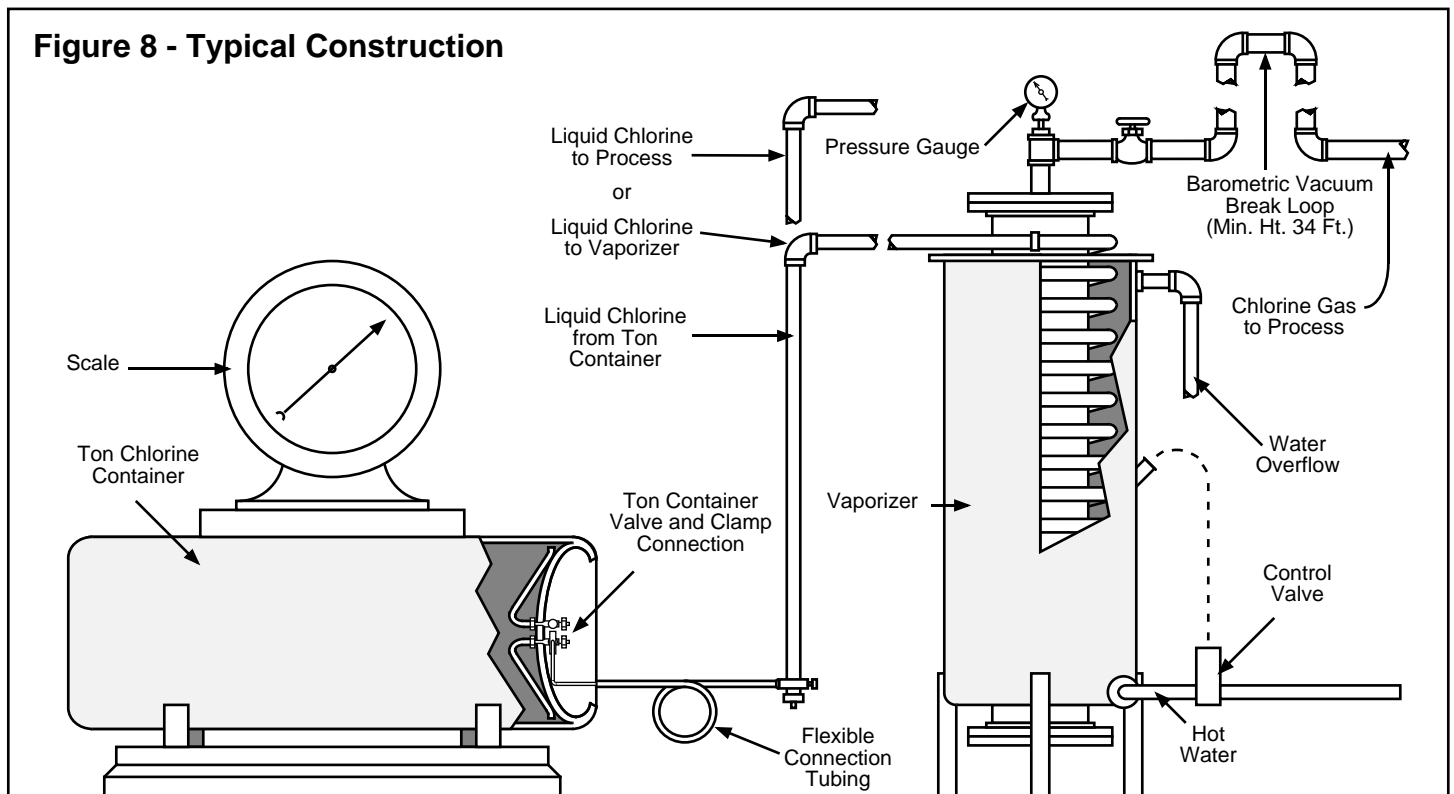

OxyChem's large fleet of tank cars comply with all specifications and regulations of the DOT. Liquid chlorine is supplied in tank cars with capacities of 55 tons and 90 tons.

The tank of most tank cars is of fusion welded steel construction, built according to DOT specifications 105A300W and 105A500W. The tank is provided with a thick covering of insulating material which in turn is protected by a steel jacket. The only opening in the tank is in the dome which contains all of the valves on the tank. (See Figures 9 and 10.)

The two angle valves parallel to the length of the tank car deliver liquid chlorine. The liquid valves are connected to eduction pipes which are equipped with excess-flow valves. The excess-flow valves are designed to stop the flow of liquid chlorine if the delivery rate exceeds 7,000 pounds/hour for a 55 ton capacity car or 15,000 pounds/hour for a 90 ton car. The angle valve must be fully opened to allow the excess-flow valve to function in case of a ruptured delivery line. (See Figure 11.)

The two angle valves at right angles to the longitudinal axis of the tank car will deliver gaseous chlorine or they can be used to apply dry air or nitrogen padding.

Average Dimensions of Tank Cars

Capacity Tons	Length (between striking plates)	Height (to valve connection)	Overall Height	Overall Width
55	42'8"	12'9"	14'6"	10'2"
90	45'8"	13'6"	14'10"	10'6"

The safety valve is located at the center of the dome, (Figure 9, Valve Number 5). On DOT 105A300W tanks, it is designed to initially relieve at a pressure of 225 psig. Following the initial relief, the valve functions as a regular spring loaded valve set at 213 psig. On a 105A500W tank, the safety valve is designed to initially relieve at a pressure of 375 psig and then it operates as a regular spring loaded valve set to discharge at 360 psig. Safety valves on chlorine tank cars must never be disturbed or tampered with under any circumstances.

The outlet of each angle valve on a tank car has one-inch standard tapered female pipe threads. This outlet is protected by a one-inch pipe plug which must be kept in place whenever the valve is not in use.

Each time a tank car is returned to OxyChem, it is subjected to a rigorous inspection. Any damaged tank car is immediately removed from service until such time as repairs can be made.

When the angle valves are removed, they are dismantled, completely reconditioned, and subjected to a static test at a pressure far greater than a normal working pressure. The excess-flow valves are inspected and cleaned at the same time. Safety valves are removed, reconditioned, and tested every two years.

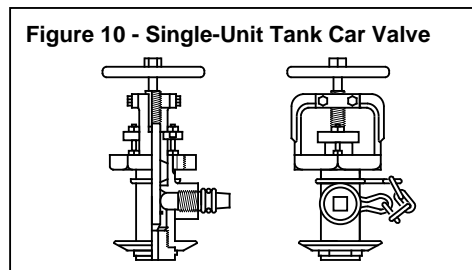
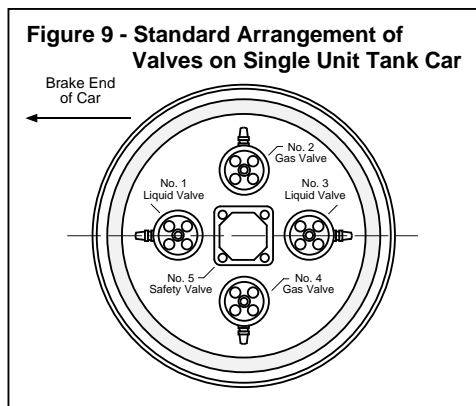

Note: Figures 9 and 10 show typical installation for the ACF angle valve.

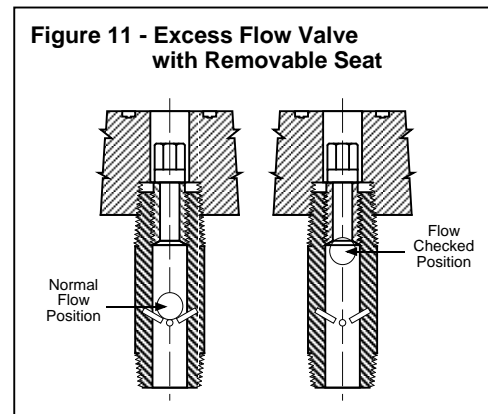

Handling and Use of Tank Cars

Single-unit tank cars must be unloaded only on the consumer's protected private track.

When a tank car of chlorine is placed on a private siding for

unloading, the brakes must be set and the wheels blocked. The following precautions are required by DOT Hazardous Materials Regulation, CFR Title 49, Paragraph

174.67, governing the transportation of hazardous materials: "Caution" signs must be placed in such a position on the track or car to warn persons approaching the car from

Figure 12 - Typical Installation

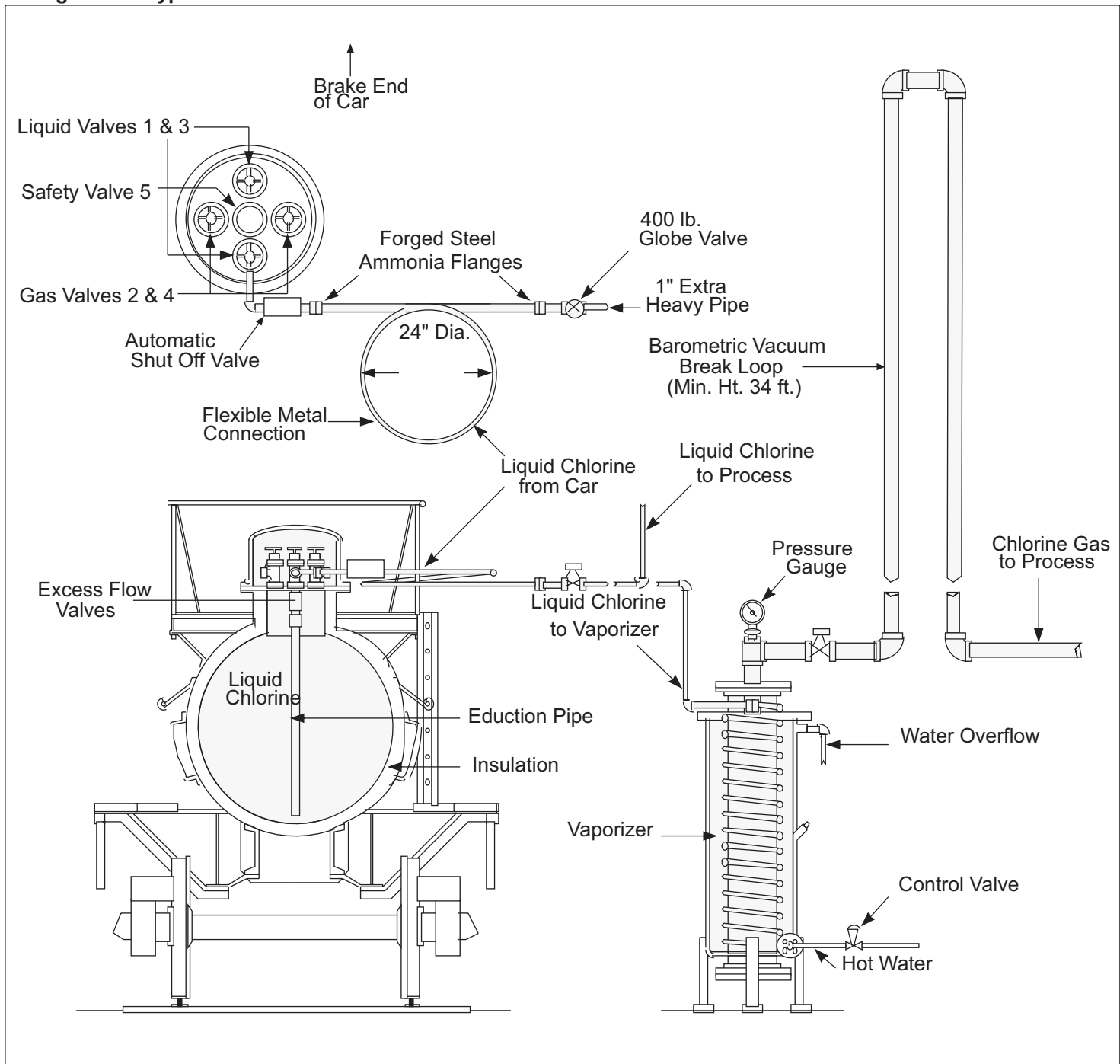

Handling and Use of Tank Cars

the open end or ends of the siding and must be left up until after the car is unloaded and disconnected from the discharge connection. Signs must be of metal, at least 12 by 15 inches in size and bear the words "STOP—Tank Car Connected" or "STOP—Men at Work." The word "STOP" must be in letters at least 4 inches high and the other words in letters at least 2 inches high. The letters must be white on a blue background.

Tank cars must be protected by a derail at the switch end or ends of a siding.

Shipping a leaking or defective tank car containing any chlorine is illegal. If a tank car is defective, call your supplier. OxyChem's 24 hour emergency number is 800/733-3665.

Use a flexible metal connection for unloading chlorine as outlined in The Chlorine Institute, Inc. Pamphlet No. 6, DWG No. 118. A typical installation is shown in the diagram in Figure 12.

Opening a liquid chlorine valve too rapidly could cause the excess-flow valve to function and stop the flow of liquid chlorine. The excess-flow valve can be unchecked by closing the chlorine valve completely and waiting until a noticeable click is heard, indicating that the metal ball has fallen back into place.

In many chlorine handling systems, additional pressure is necessary for unloading at a normal or accelerated rate. Under these conditions, dry air (dew point of -40°F) must be used.* A separate plant air

drying system is needed for this operation.

Safe padding pressure limits are defined by the setting of the pressure relief valve and the temperature of the liquid chlorine. Padding pressure limits for chlorine tank cars can be found in the The Chlorine Institute, Inc., Drawing # 201.

For additional information on the handling and use of tank cars refer to The Chlorine Institute, Inc., Pamphlet # 66.

* Dry nitrogen may also be used in most cases.

Cargo Tank Trucks

DOT issued CFR Title 49, gives the MC331 specification for cargo tank trucks authorized for chlorine use in the United States and Canada.

Chlorine cargo tank trucks meeting DOT Specification MC331 or MC330 have an approximate capacity of 15 to 20 tons. The only opening in a chlorine cargo tank truck is in the dome which contains all of the required valves. The two angle valves parallel to the length of the tank will deliver liquid chlorine. The liquid valves are connected to eduction pipes which are equipped with excess-flow valves. The excess-flow valves are designed to stop the flow of liquid chlorine if the delivery rate exceeds 7,000 pounds per hour.

The two angle valves at right angles to the longitudinal axis of the tank will deliver gaseous chlorine. They are also equipped with excess-flow valves, but of a different design.

The outlet of each angle valve on a chlorine cargo tank truck has one-inch standard tapered female pipe threads. This outlet is protected by a one-inch pipe plug which should be kept in place whenever the valve is not in use.

The safety valve is located at the center of the dome, between the angle valves. It is designed to initially relieve at a pressure of 225 psig. Subsequent to relief, the valve functions as a regular spring loaded valve set at 213 psig.

Handling and Use of Chlorine Cargo Tank Trucks

In general, chlorine can be shipped in cargo tank trucks only if the contents are to be unloaded at one unloading point. For this reason, Occidental Chemical will assist in any individual study or evaluation to determine if tank truck shipments of chlorine are feasible.

Tank Truck Unloading—Air Padding

In many chlorine handling systems, additional pressure is necessary for unloading at a normal or accelerated rate. Under these conditions, dry air (dew point of -40°F) must be used.* A separate plant air drying system is needed for this operation.

For additional information on chlorine tank motor vehicles, refer to The Chlorine Institute, Inc. Pamphlet No. 49.

* Dry nitrogen may also be used in most cases.

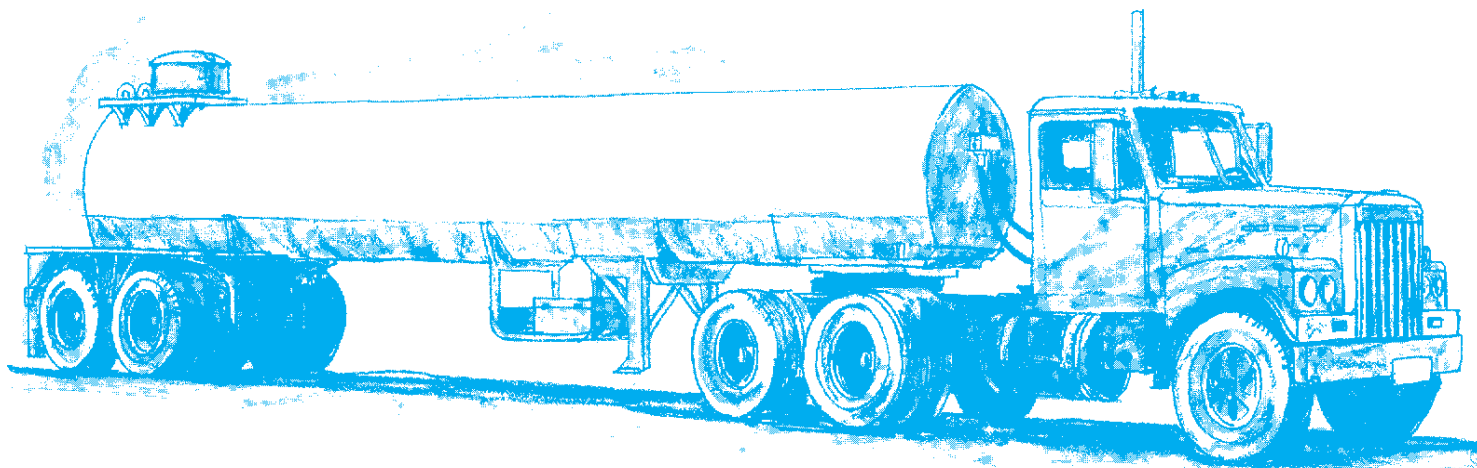

In general, pipelines for handling chlorine should be fabricated from extra-heavy, black-iron pipe. Joints must be welded or flanged. Fittings must be eliminated wherever possible.

Valves for chlorine service should be constructed of forged steel. Packing for these valves should be either PTFE or flexible graphite. For additional information on valves for chlorine service please consult The Chlorine Institute, Inc., Pamphlet # 6.

The use of valves in pipelines must balance minimizing accidental release and reducing fugitive emissions. Liquid chlorine has a high coefficient of thermal expansion. If liquid chlorine is trapped between two valves, high pressure may develop and lead to a rupture of the line or its fittings. Expansion chambers, installed at the highest point in the section may be needed. Expansion chambers are fabricated from extra-heavy pipe and have a capacity equal to at least 20 volume percent of the protected section of pipe.

For more information on piping systems, consult The Chlorine Institute, Inc., Pamphlets # 6 and 60.

Chlorine Vaporizer

When large amounts of gaseous chlorine are required for a specific process, it is advisable to remove the chlorine from the manufacturer's container as a liquid and pass it through a vaporizer to convert it to a gas. In this manner much more gaseous chlorine can be sent to process than would otherwise be possible. Rapid removal of gaseous chlorine from a container will cool the remaining liquid chlorine to a point where no chlorine vapor will flow into the process. The use of a vaporizer supplies sufficient heat to the liquid chlorine from an outside source so that the temperature of the chlorine supply remains relatively constant. Figure 8 shows a typical installation using a vaporizer to obtain gaseous chlorine from a ton container. Figure 12 shows a typical installation using a vaporizer to obtain gaseous chlorine from a single-unit tank car.

For more information on Chlorine Vaporizers, consult The Chlorine Institute, Inc. Pamphlet No. 9.

Pressure Drop in Liquid Chlorine Lines

Any liquid passing through a pipeline suffers a loss in pressure due to the resistance to flow offered by the pipeline. A further loss in pressure or head is experienced when the liquid is elevated. For every foot in elevation that liquid chlorine is raised, there is a loss in pressure of about 0.635 psi which should be added to the pressure losses due to the resistance of the piping.

The graph on page 16 shows the calculated pressure drop for liquid chlorine flowing through SCH 80 pipe of various dimensions. When valves and fittings are included in the piping system, the additional pressure loss can be readily computed by converting the friction loss in the valves and fittings to equivalent lengths of straight pipe. The data below are taken from Crane Company Technical Paper No. 409.

Equivalent Length of Pipe in Feet

Fitting	1"	3/4"	1/2"
Globe Valve (full open)	28.3	21.3	14.2
Angle Valve (full open)	12.0	9.0	6.0
Standard T (through the branch)	4.8	3.6	2.7
Long Radius Ell	1.6	1.2	0.9

Technical Data

Pressure Drop for Liquid Chlorine Flowing in New Steel Pipe

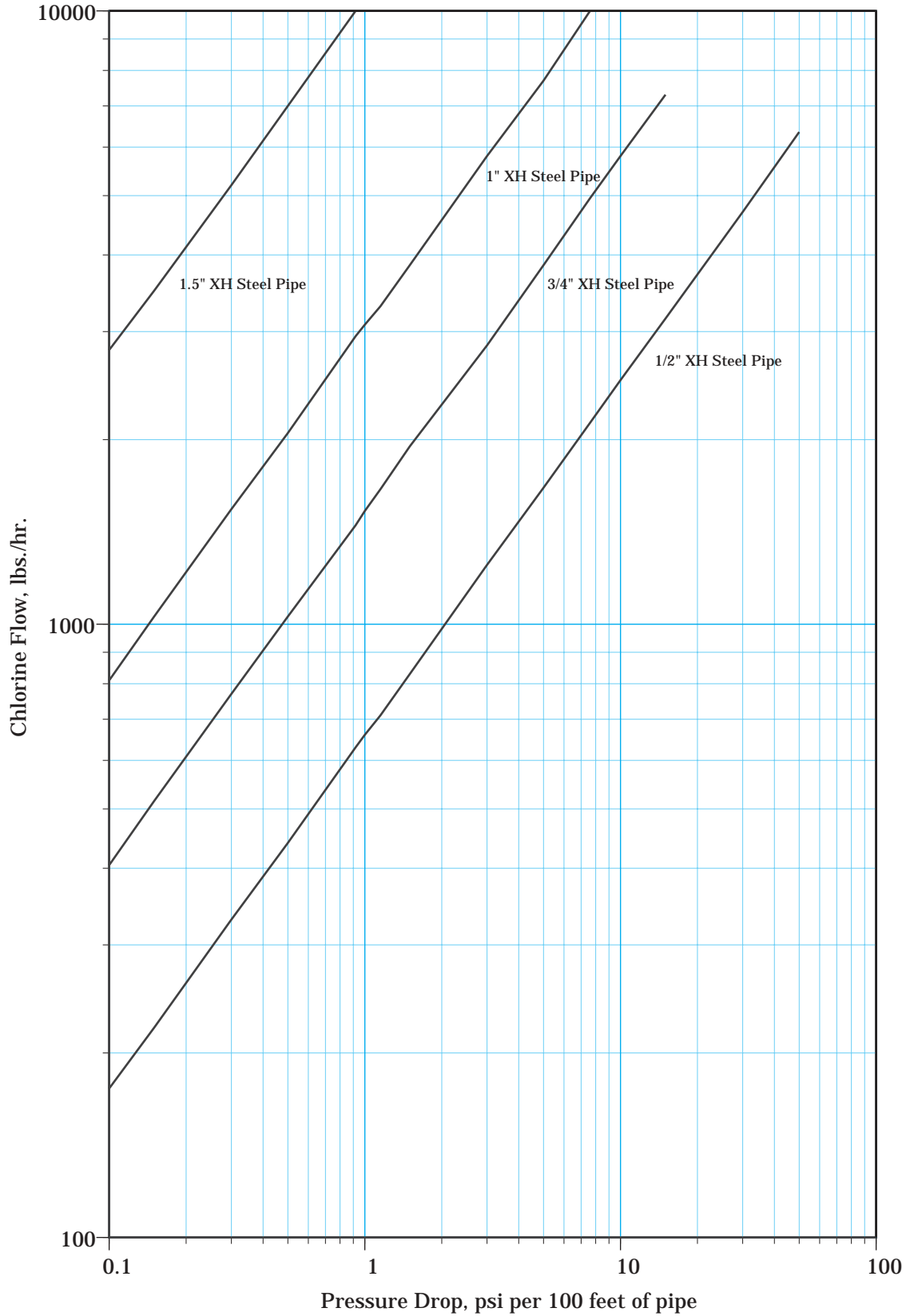

All personnel engaged in handling chlorine must be thoroughly instructed in the necessary precautions for the safe handling, storage, and use of chlorine. Carefully study everything in this manual.

Read the MSDS before use.

Chlorine is a chemical element. Neither the gas nor the liquid alone is explosive or flammable. Both react chemically with many substances, especially at elevated temperatures. The gas is greenish-yellow in color at high concentrations. It has a penetrating odor, and is two-and-one-half times as heavy as air. If it escapes from a container or system, it will seek the lowest level in the building or area in which the leak occurs. Training should include the use of safety equipment and first aid procedures.

EMPLOYEE PROTECTION

Do not breathe chlorine vapors. Chlorine irritates the mucous membranes, respiratory tract, and eyes. Smoking can aggravate the respiratory symptoms which result from chlorine exposure. Prolonged exposure to the gas causes coughing, gagging, and may result in pulmonary edema and death. Individuals with respiratory problems should consult a physician before working with chlorine.

Avoid contact with eyes, skin, and clothing. Gaseous chlorine hydrolyzes in the presence of moisture, forming hydrochloric acid, which irritates the eyes and skin. Liquid chlorine removes body heat, freezing exposed skin.

Wash thoroughly after handling chlorine. Shower, using plenty of soap and water.

Safety Equipment

Use goggles, rubber gloves, rubber shoes, hard hat, and a NIOSH approved respirator with an acid gas cartridge where airborne concentrations are expected to exceed exposure limits or when symptoms have been observed that are indicative of overexposure. It is essential that each individual who may be exposed to chlorine carry, at all times, a respirator approved for

chlorine use. For re-entry into an emergency area, self-contained breathing equipment must be used.

EQUIPMENT & EMERGENCY PROCEDURES

Ventilation

Provide adequate ventilation to reduce the accumulation of liquid or gaseous chlorine in low areas. In some cases, natural ventilation may be adequate; in others, artificial ventilation, such as forced air through a system of ducts, must be provided. A one to four minute rate of air change is required in an emergency. Precautions must be taken to avoid discharging chlorine into areas where it can cause damage or personal injury.

Eye Wash Fountains and Deluge Showers

Readily accessible eye wash fountains and deluge showers must be provided in strategic locations wherever chlorine is used. Personnel should test equipment each day before beginning work to ensure adequate water flow.

Emergency Respiratory Protection

Severe exposure to chlorine may occur wherever chlorine is handled or used. Therefore, self-contained positive pressure breathing apparatus, approved for emergency chlorine use, should be located strategically outside chlorine work areas near entrances and away from contamination. Such equipment shall have a rating of at least 30 minutes use, and be equipped with a low pressure warning bell. Any person entering a chlorine emergency area must be protected by this respiratory protective equipment.

Emergency Kits

In an emergency involving chlorine cylinders, ton containers, tank cars, or barges, kits are available which can be used to stop leaks. Chlorine emergency kits are maintained by producers and are located strategically throughout the United States and Canada. In addition, kits are available from other chlorine

users and distributors, and the location of these kits can be found in The Chlorine Institute, Inc. Pamphlet No. 35, "Location of Chlorine Emergency Kits." Obtain a copy and note the nearest source, or purchase kit(s) from an approved supplier.

OTHER EMERGENCY MEASURES

The Chlorine Institute, Inc. was formed over 50 years ago by chlorine producers to promote the safe use of chlorine and to standardize chlorine handling equipment. The Institute also sponsors a mutual assistance program in which trained teams respond to chlorine emergencies on a 24-hour-a-day, 7-day-a-week basis. In the United States, this response program is known as CHLOREP (Chlorine Emergency Plan). The United States is divided into 32 sectors with CHLOREP teams available from 49 plant sites (one to three plant sites in each sector).

CHLOREP is now affiliated with CHEMTREC (The Chemical Transportation Emergency Center) maintained by the Chemical Manufacturers Association (CMA) in Washington, D.C. Assistance can be summoned by calling either CHEMTREC (Toll free 1-800-424-9300) or the appropriate CHLOREP team.

Canada is divided into ten regions with teams available from 13 plant



Safety and Emergency Information

sites as established by TEAP (Transportation Emergency Assistance Plan) of the Canadian Chemical Producers' Association. In Canada, assistance is available by calling either the TEAP regional number or the appropriate response team.

In both the United States and Canada, these teams provide assistance in any chlorine emergency whether a transportation incident or a problem at the point of usage. Chlorine users must have the telephone number of their response team(s) readily available for use in chlorine emergency situations.

Chlorine users must accept responsibility for taking all proper precautions to prevent accidents with chlorine. The fact that emergency assistance is available should not encourage carelessness in the use of this chemical.

HANDLING AND STORAGE

Store cylinders and ton containers in a dry, ventilated, fire resistant area separate from metals, organic, or inorganic chemicals. All valves must be kept tightly closed until

containers are connected for unloading. Protect from heat and direct sunlight.

In Case of Fire

Chlorine itself will not burn, but it does act as an oxidizer and supports combustion, even in the absence of oxygen. Cool the affected containers with large amounts of water. Use any other extinguishing medium appropriate for the surrounding fire. All fires liberate toxic gases. Use self-contained breathing apparatus and full protective equipment.

Leaks

Do not apply water directly on a chlorine leak. Moisture hydrolyzes chlorine, forming hydrochloric acid which attacks the metal, thus enlarging the leak. If a container is leaking chlorine, position the container so that gas escapes instead of liquid. The quantity of escaping chlorine is significantly less from a gas leak than a liquid leak, since one volume of liquid is equal to about 460 volumes of gas. Evacuate the area and keep all personnel

upwind of leaks, preferably on high ground. Secure self-contained breathing apparatus. Shut chlorine supply off at source.

Water Disposal

Absorb chlorine in an alkaline solution (caustic soda, soda ash, or hydrated lime) while maintaining an excess of base at all times (see below).^{*} Destroy resulting hypochlorite by adding sodium sulfite or treating the basic hypochlorite at 122°-158°F (50°-70°C) in the presence of copper, nickel, or iron. Control pH at the discharge to sewer or the receiving water and comply with all applicable federal, state, and local regulations.

Recommended Alkaline Solutions for Absorbing Chlorine

Size of Chlorine Container (Pounds Net)	100% Caustic Soda		100% Soda Ash		100% Hydrated Lime	
	Pounds	Water (gallons)	Pounds	Water (gallons)	Pounds	Water (gallons)
100	125	60	300	200	115	125
150	188	90	450	300	175	188
2000	2500	1200	5980	4000	2325	2500

^{*} Slurry must be continuously and vigorously agitated if chlorine is to be absorbed 100%.

FIRST AID

Exposure Symptoms

Liquid chlorine is a skin and eye irritant. Prolonged contact produces burns. Liquid chlorine slowly vaporizes to gas in the open atmosphere. At detectable odor levels, the gas will irritate the mucous membranes and respiratory tract. (Detectable odor levels range from 0.3 to 3.0 ppm depending on the individual.) With excessive exposure to chlorine, the individual exhibits excitement, accompanied by restlessness, sneezing, and copious salivation. In extreme cases, retching, pulmonary edema, and even death may occur.

There are no specific known antidotes for chlorine. Effective medical management is necessary for relief of symptoms with proper treatment. Complete recovery normally occurs.

Inhalation

If chlorine is inhaled, move the individual to fresh air. If breathing is difficult, have a trained person administer oxygen. If respiration stops, have a trained person administer artificial respiration.

Treatment for inhalation must precede first aid given to other body areas affected by exposure to chlorine.

Skin

In case of contact, immediately remove the contaminated clothing and shoes. Flush skin with plenty of water. Never attempt to neutralize the chlorine with chemicals. Salves and ointments should not be applied unless directed by a physician. Wash clothing before re-use. Discard contaminated nonrubber shoes. **GET MEDICAL ATTENTION IMMEDIATELY**

Eyes

In case of eye contact, immediately flush eyes with a directed stream of water (low pressure-high volume) for 15 minutes. Forcibly hold eyelids apart to ensure complete irrigation of all eye and lid tissues. An eye wash fountain is ideal for this type of treatment. **GET MEDICAL ATTENTION IMMEDIATELY.**

Ingestion

Due to its physical properties, swallowing liquid chlorine is extremely unlikely. In such an instance, call a physician immediately.

Notes to Physician

Because there is no known antidote for chlorine gas inhalation, treatment is symptomatic. The effective and immediate relief of symptoms is the primary goal. Steroid therapy, if given early, has been reported effective in preventing pulmonary edema.

EMPLOYEE TRAINING FOR SAFE OPERATIONS

Safety in handling chlorine depends, to a great extent, upon the effectiveness of employee education, proper safety instructions, effective supervision, and the use of proper personal protective equipment.

Supervisory personnel are responsible for providing proper instruction and training of employees. Training for all employees should be conducted periodically, to reinforce correct methods and to maintain a high degree of competence in handling procedures. All new employees must be trained in handling and using chlorine before operating equipment. Employees should be thoroughly familiar with the hazards that may result from improper handling of chlorine. Each employee should know emergency and first aid measures, and how to use associated equipment.

As a minimum, employee training should include the following:

- A) Instruction with periodic drills regarding the locations, purpose, limitations, and use of chlorine emergency kits, fire fighting equipment, fire alarms, and shutdown equipment such as valves and switches.
- B) Instruction with periodic drills regarding the locations, purpose, limitations, and use of personal protective equipment, both normal and emergency.
- C) Instruction with periodic drills regarding the locations, purpose, and use of safety showers, eye baths, or the closest source of water for use in emergencies.

- D) Instruction with periodic drills for specified employees on each work shift/period regarding the locations, purpose, and use of emergency respiratory protection and first aid equipment.
- E) Instruction on avoiding inhalation of chlorine gas and contact with the liquid. Emphasis should be placed on chlorine's effect on the human body at different exposure levels.
- F) Instruction on procedures for reporting all equipment failures to the proper authority.
- G) Instruction on procedures for conducting inspections before working with equipment, and periodically during operations. This instruction should include procedures for recognizing leaks and other potential problems.
- H) Instruction on the proper actions to take when leaks occur and on procedures for evacuating affected areas.

Technical Data

Physical Properties of Chlorine

Atomic weight: 35.453
 Boiling point: -34.05°C (-29.29°F)
 Freezing point: -100.98°C (-149.76°F)
 Critical temperature: 144.0°C (291.2°F)
 Critical pressure: 7711 kPa (76.1 atm, 1118 psi)
 Critical volume: $1.745 \times 10^{-3} \text{ m}^3/\text{kg}$ (0.02796 cu ft/lb)
 Heat of fusion at the melting point: $6405 \pm 5 \text{ J/mol}$
 (38.86 Btu/lb)

Viscosity of Chlorine Gas at 1 Atm	
°C	cp.
-30	0.0112
0	0.0126
100	0.0169
200	0.021
300	0.025
Thermal Conductivity of Chlorine Gas at 1 Atm	
°C	Btu/(hr-ft-°F)
-30	0.0042
0	0.0048
100	0.0067
200	0.0086
300	0.0103
Thermal Conductivity of Liquid Chlorine	
°C	Btu/(hr-ft-°F)
-100	0.1149
0	0.0847
100	0.0532
144	0.0230

Conversion of Units

Physical Quantity	SI Unit	Conversion
Concentration	kilograms per cubic meter	$1 \text{ kg/m}^3 = 0.008345 \text{ lbs/gal}$
Density	kilograms per cubic meter	$1 \text{ kg/m}^3 = 0.062428 \text{ lbs/cu ft}$
Energy	joules per kilogram	$1 \text{ J/kg} = 0.000430 \text{ Btu/lb}$
Entropy	joules per kilogram-Kelvin	$1 \text{ J/kg-}^\circ\text{K} = 0.000239 \text{ Btu/lb-}^\circ\text{F}$
Pressure	Pascals (Newtons per square meter)	$1 \text{ Pa} = 0.000145 \text{ psi}$ $1 \text{ Pa} = 9.86923 \times 10^{-6} \text{ atm}$
Surface Tension	joules per square meter	$1 \text{ J/m}^2 = 0.068522 \text{ lb(force)/ft}$ $1 \text{ J/m}^2 = 1000 \text{ ergs/cm}^2$
Temperature	Kelvin	$^\circ\text{K} = ^\circ\text{C} + 273.15$ $^\circ\text{C} = (^\circ\text{F} - 32) / 1.8$
Thermal Conductivity	watts per meter-Kelvin	$1 \text{ W/m-}^\circ\text{K} = 0.577797 \text{ Btu/(hr-ft-}^\circ\text{F)}$
Viscosity	Pascal-second	$1 \text{ Pa-s} = 0.671969 \text{ lb/ft-sec}$ $1 \text{ Pa-s} = 1000 \text{ centipoise}$
Volume	cubic meters per kilogram	$1 \text{ m}^3/\text{kg} = 16.0185 \text{ cu ft/lb}$

Technical Data

Thermodynamic Properties of Saturated Chlorine

(Base: $h = 0, s = 0$ for solid Cl_2 at $0^\circ R$)

Temp (°F)	Absolute Pressure (psi)	Volume (cu ft/lb)		Enthalpy (Btu/lb)			Entropy (Btu/lb-°R)		
		Liquid	Vapor	Liquid	Vaporization	Vapor	Liquid	Vaporization	Vapor
t	p	v _l	v _g	h _l	h _g	h _g	s _l	s _g	s _g
-130	0.51902	0.0093981	95.993	78.488	137.13	215.57	0.37472	0.41593	0.79065
-120	0.80251	0.0094727	63.930	80.890	135.72	216.61	0.38201	0.39956	0.78158
-110	1.2055	0.0095492	43.776	83.305	134.35	217.65	0.38901	0.38420	0.77322
-100	1.7643	0.0096277	30.738	85.697	133.00	218.69	0.39575	0.36976	0.76551
-90	2.5213	0.0097083	22.081	88.067	131.66	219.73	0.40225	0.35615	0.75840
-80	3.5258	0.0097911	16.193	90.420	130.34	220.76	0.40852	0.34328	0.75181
-70	4.8336	0.0098761	12.101	92.759	129.02	221.78	0.41459	0.33110	0.74570
-60	6.5073	0.0099636	9.1996	95.087	127.71	222.80	0.42048	0.31954	0.74003
-50	8.6157	0.010053	7.1037	97.406	126.40	223.81	0.42620	0.30854	0.73474
-40	11.234	0.010146	5.5642	99.719	125.08	224.80	0.43177	0.29805	0.72982
-30	14.443	0.010242	4.4156	102.02	123.76	225.79	0.43719	0.28802	0.72522
-29.29	14.696	0.010248	4.3457	102.19	123.66	225.86	0.43757	0.28732	0.72490
-20	18.329	0.010340	3.5462	104.33	122.41	226.75	0.44248	0.27842	0.72090
-10	22.984	0.010442	2.8793	106.64	121.05	227.70	0.44765	0.26920	0.71686
0	28.504	0.010547	2.3613	108.95	119.67	228.63	0.45271	0.26033	0.71305
10	34.987	0.010656	1.9544	111.27	118.26	229.53	0.45767	0.25179	0.70946
20	42.538	0.010768	1.6313	113.59	116.82	230.41	0.46252	0.24354	0.70606
30	51.265	0.010885	1.3722	115.92	115.34	231.26	0.46729	0.23555	0.70284
40	61.276	0.011006	1.1625	118.25	113.83	232.09	0.47196	0.22781	0.69978
50	72.684	0.011132	0.99128	120.59	112.28	232.88	0.47656	0.22029	0.69686
60	85.606	0.011263	0.85030	122.95	110.68	233.63	0.48109	0.21297	0.69406
70	100.15	0.011399	0.73335	125.32	109.02	234.35	0.48555	0.20583	0.69138
80	116.45	0.011541	0.63565	127.71	107.31	235.02	0.48994	0.19885	0.68879
90	134.63	0.011690	0.55346	130.11	105.54	235.65	0.49428	0.19200	0.68629
100	154.80	0.011846	0.48388	132.53	103.70	236.23	0.49857	0.18528	0.68385
110	177.09	0.012009	0.42462	134.98	101.78	236.76	0.50281	0.17866	0.68148
120	201.64	0.012181	0.37386	137.45	99.782	237.24	0.50702	0.17213	0.67915
130	228.57	0.012362	0.33014	139.96	97.685	237.65	0.51121	0.16565	0.67686
140	258.03	0.012554	0.29228	142.51	95.483	237.99	0.51537	0.15922	0.67459
150	290.14	0.012758	0.25934	145.09	93.162	238.26	0.51953	0.15280	0.67233
160	325.05	0.012975	0.23052	147.73	90.709	238.44	0.52368	0.14637	0.67006
170	362.91	0.013208	0.20520	150.43	88.105	238.54	0.52786	0.13991	0.66778
180	403.86	0.013458	0.18285	153.20	85.328	238.53	0.53206	0.13339	0.66545
190	448.07	0.013728	0.16301	156.06	82.354	238.41	0.53631	0.12676	0.66307
200	495.68	0.014023	0.14533	159.01	79.150	238.16	0.54063	0.11998	0.66061
210	546.88	0.014348	0.12947	162.07	75.677	237.75	0.54504	0.11300	0.65805
220	601.82	0.014710	0.11518	165.28	71.882	237.16	0.54958	0.10575	0.65534
230	660.70	0.015118	0.10221	168.66	67.696	236.36	0.55428	0.098155	0.65243
240	723.69	0.015587	0.090340	172.25	63.022	235.28	0.55919	0.090072	0.64926
250	790.99	0.016143	0.079352	176.13	57.713	233.84	0.56440	0.081322	0.64573
260	862.81	0.016827	0.069011	180.38	51.528	231.90	0.57004	0.071598	0.64164
270	939.35	0.017729	0.058995	185.19	44.007	229.20	0.57635	0.060310	0.63666
280	1020.8	0.019102	0.048647	191.04	33.987	225.03	0.58393	0.045948	0.62987
290	1107.5	0.022862	0.034207	200.80	14.060	214.86	0.59658	0.018756	0.61534
291.2	1118.37	0.027960	0.027960	207.77	00.000	207.77	0.60582	0.000000	0.60582

REF: Kapoor, R.M.; Martin, J.J., Thermodynamic Properties of Chlorine, Engineering Research Institute, University of Michigan, Ann Arbor, Michigan (1957).

Density of Liquid Chlorine

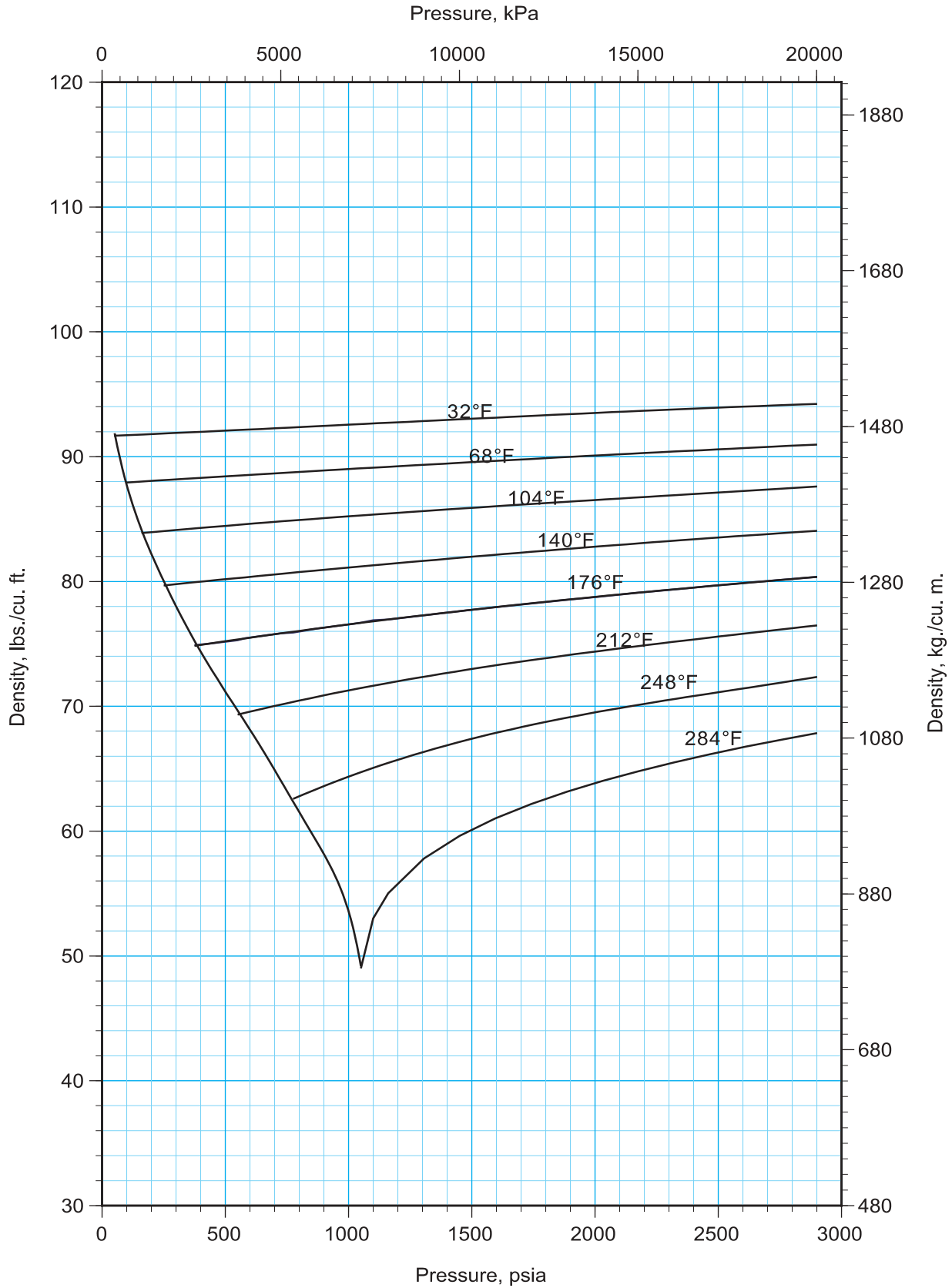

Technical Data

Specific Heat (Heat Capacity) of Liquid Chlorine

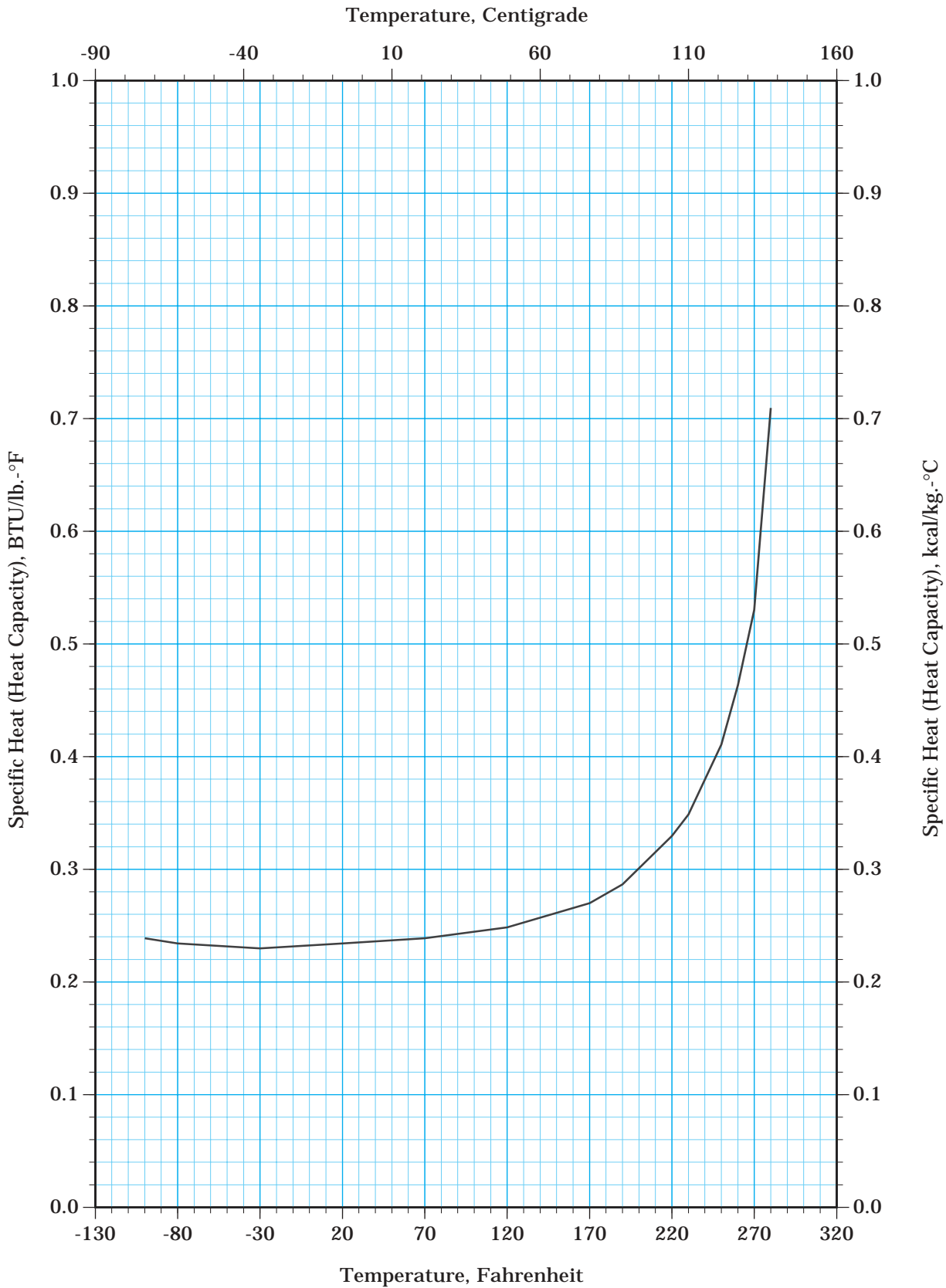

Specific Heat (Heat Capacity) of Chlorine Gas

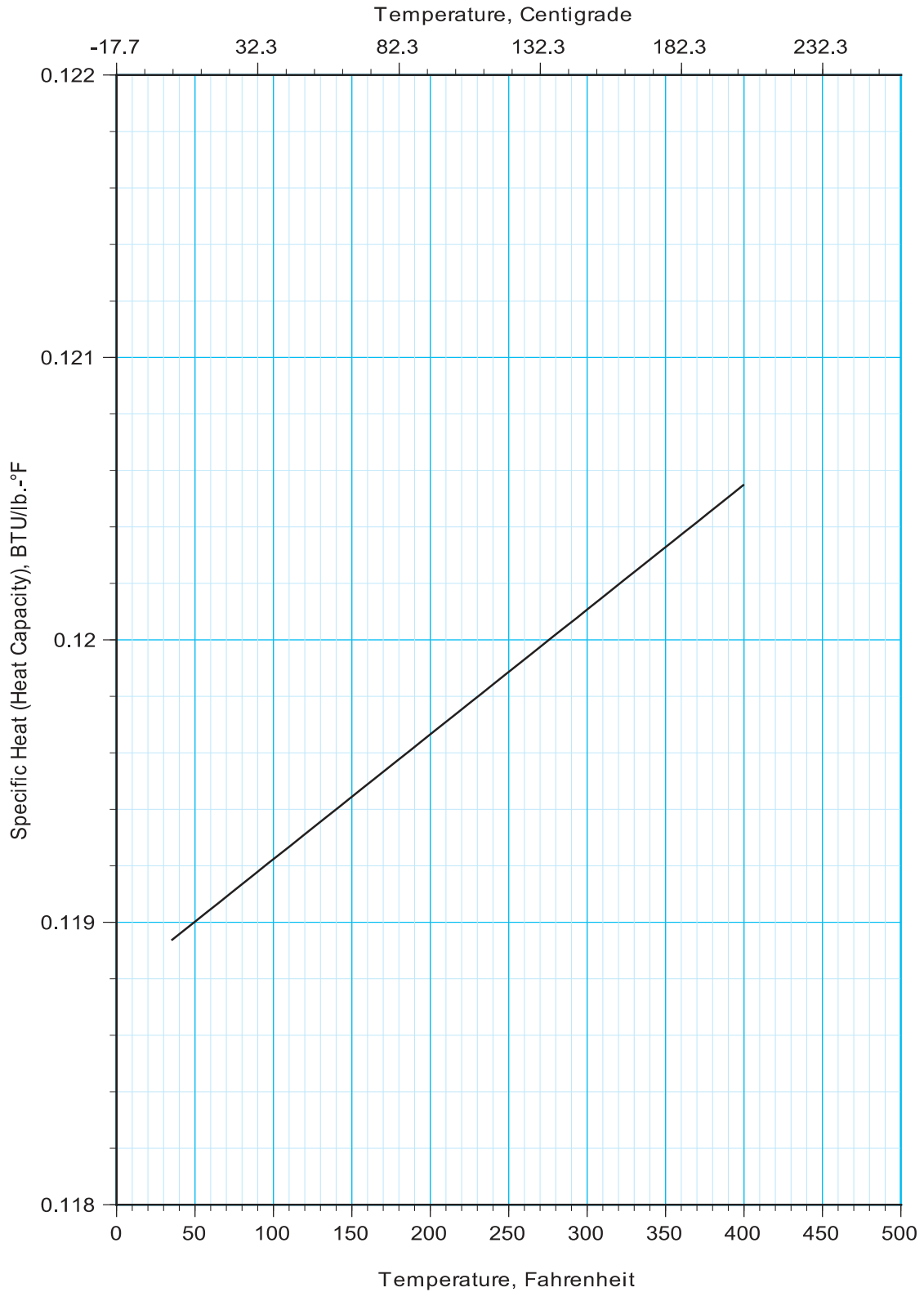

Technical Data

Latent Heat of Vaporization of Chlorine

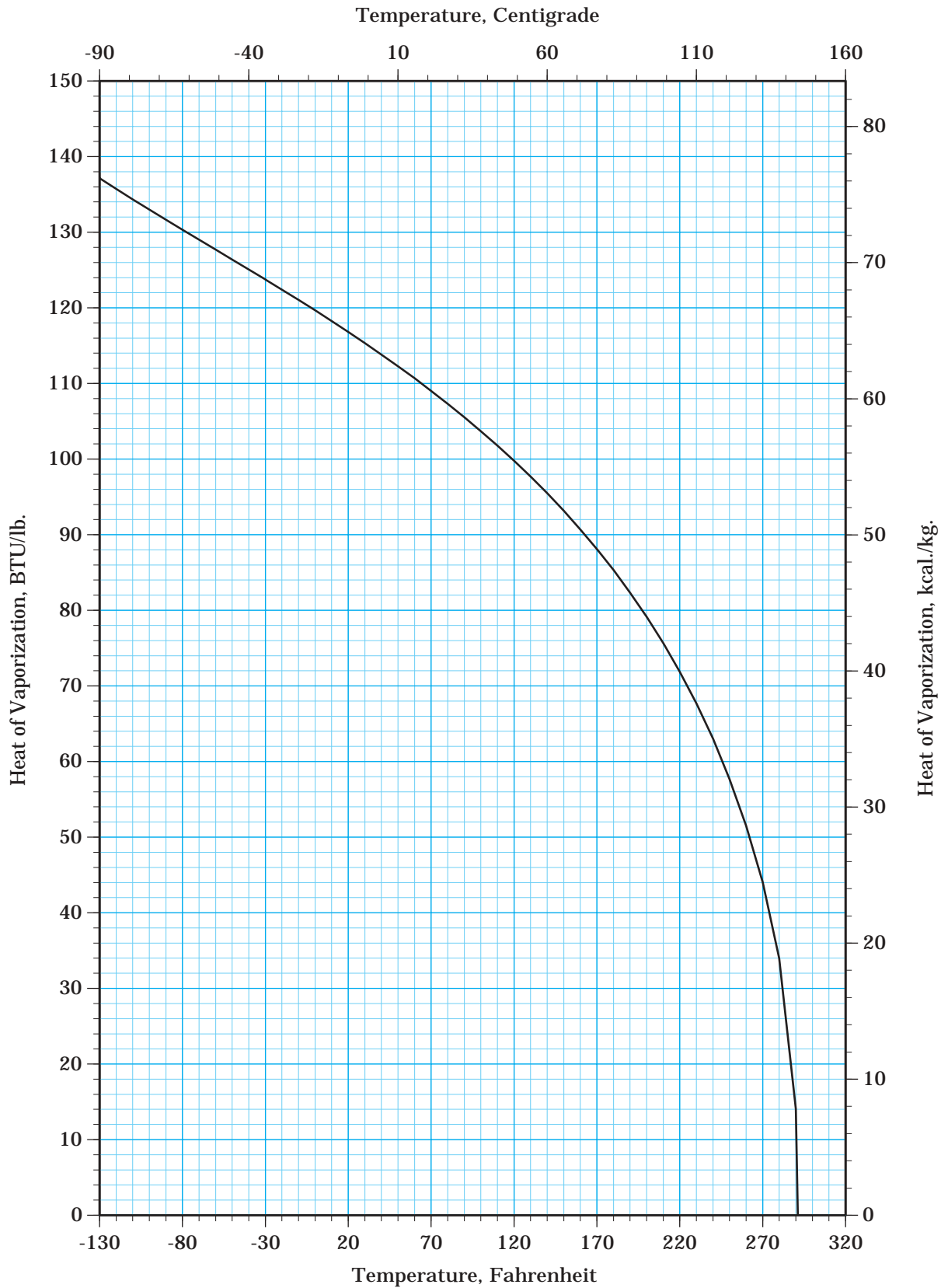

Solubility of Chlorine in Water

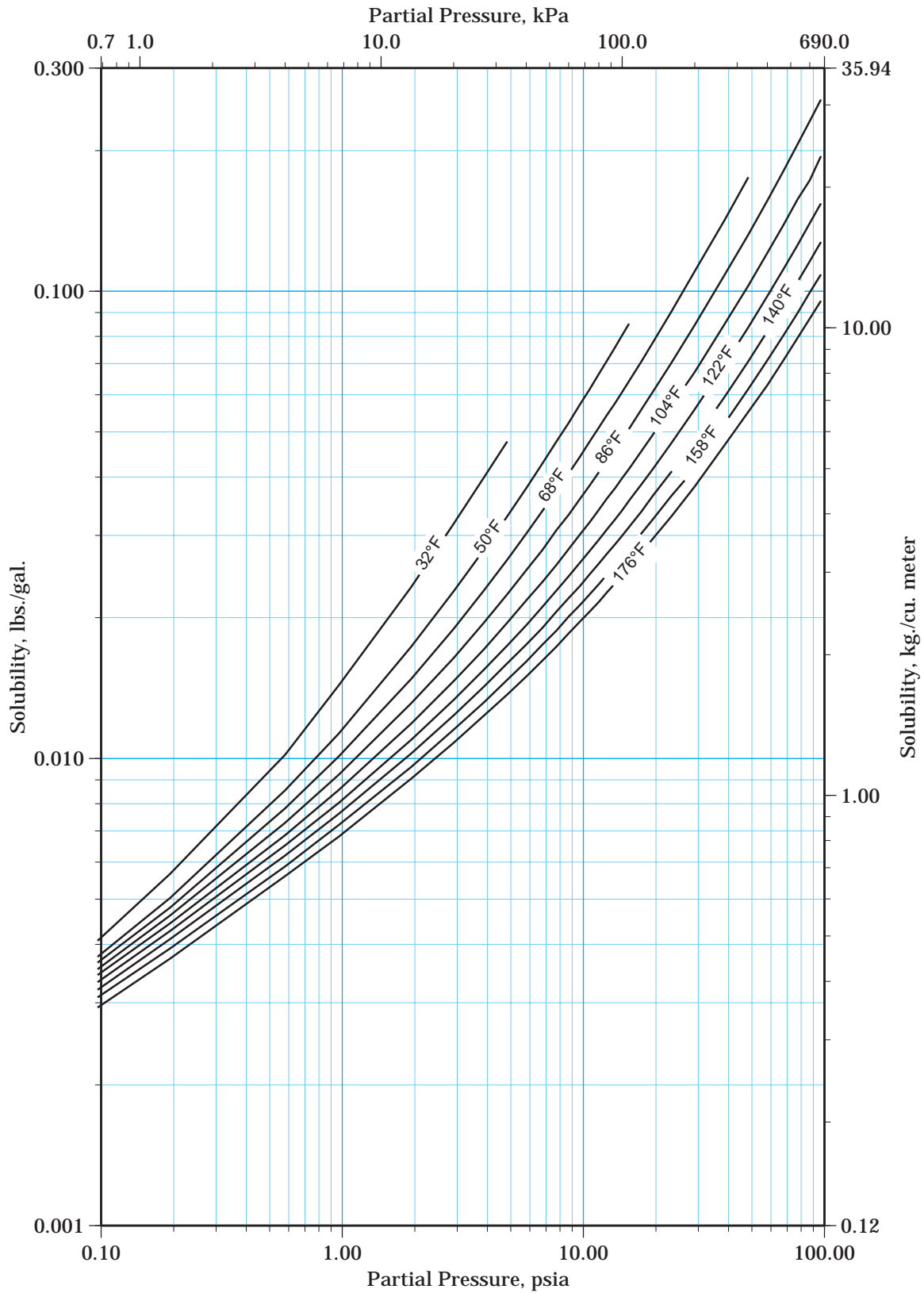

Technical Data

Vapor Pressure of Saturated Chlorine

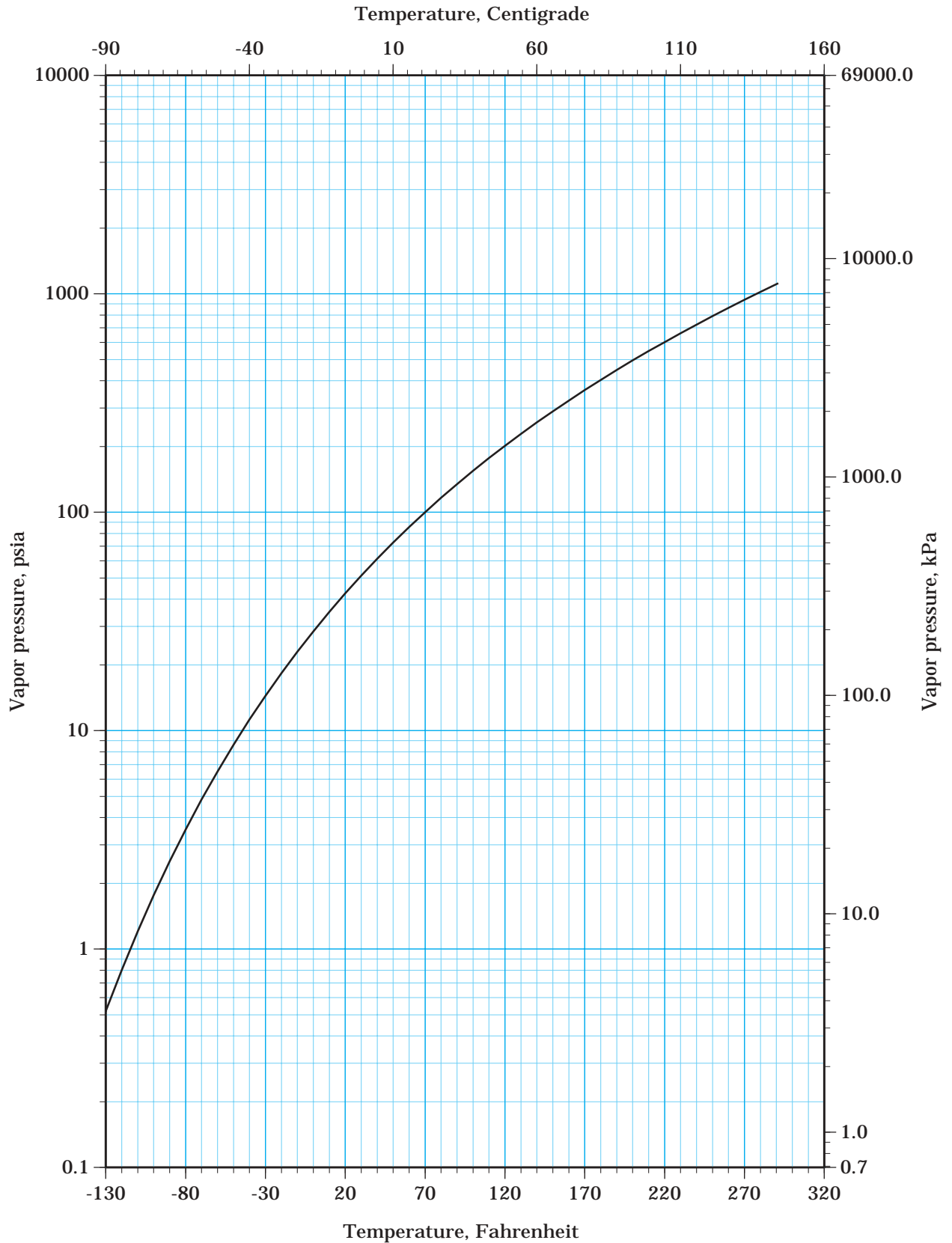

Viscosity of Liquid Chlorine

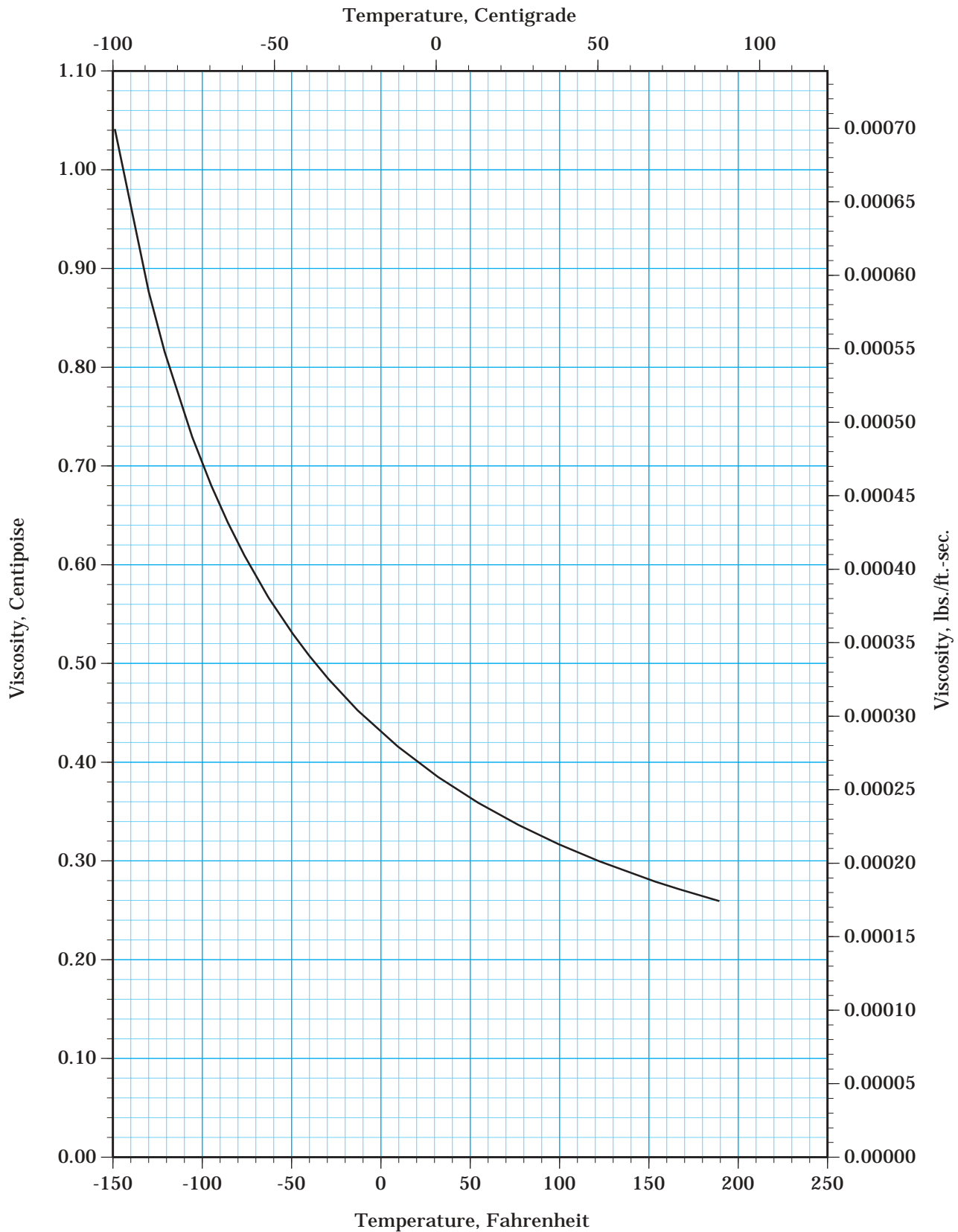

Technical Data

Viscosity of Chlorine Gas

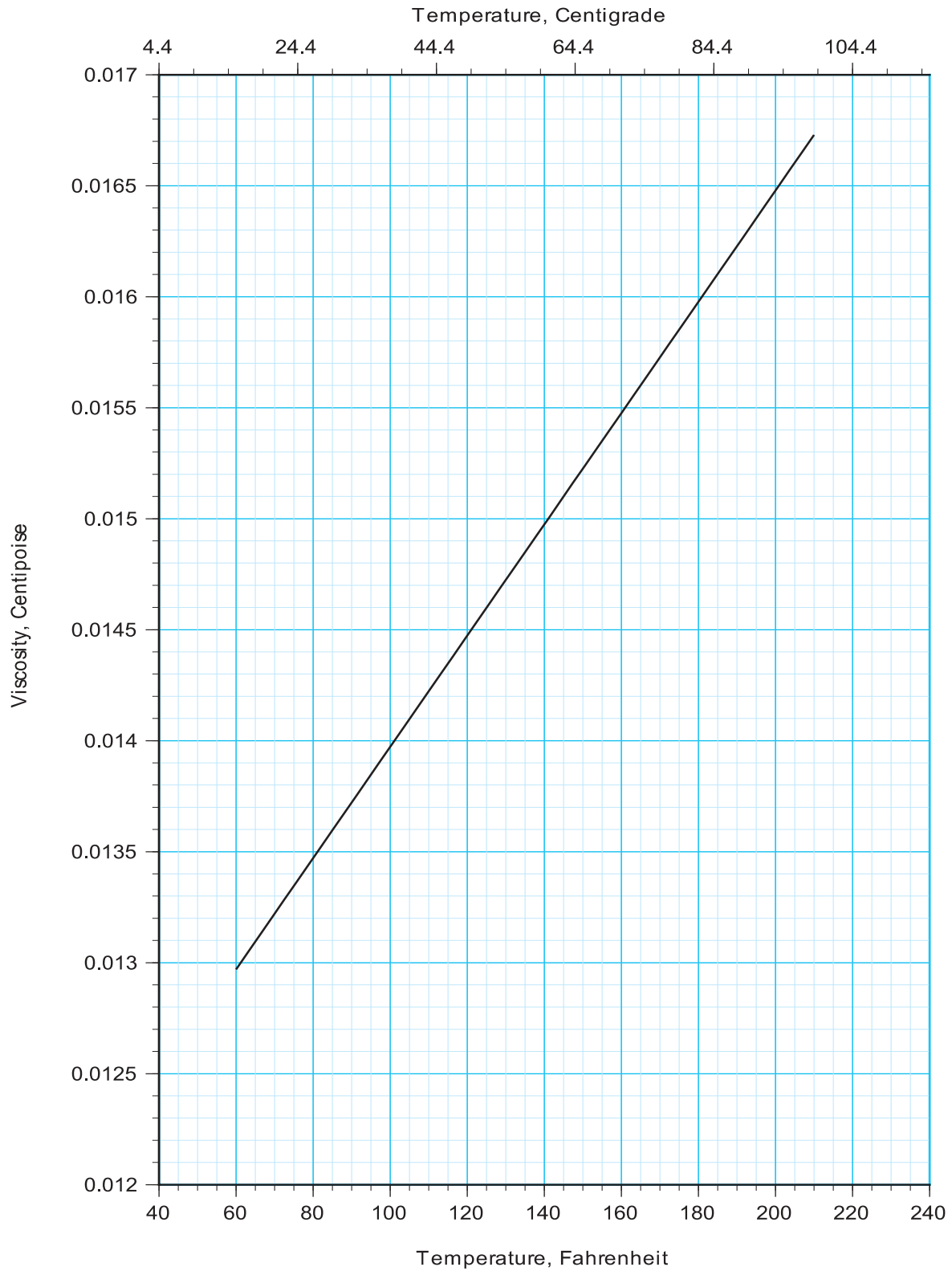

Enthalpy of Liquid Chlorine

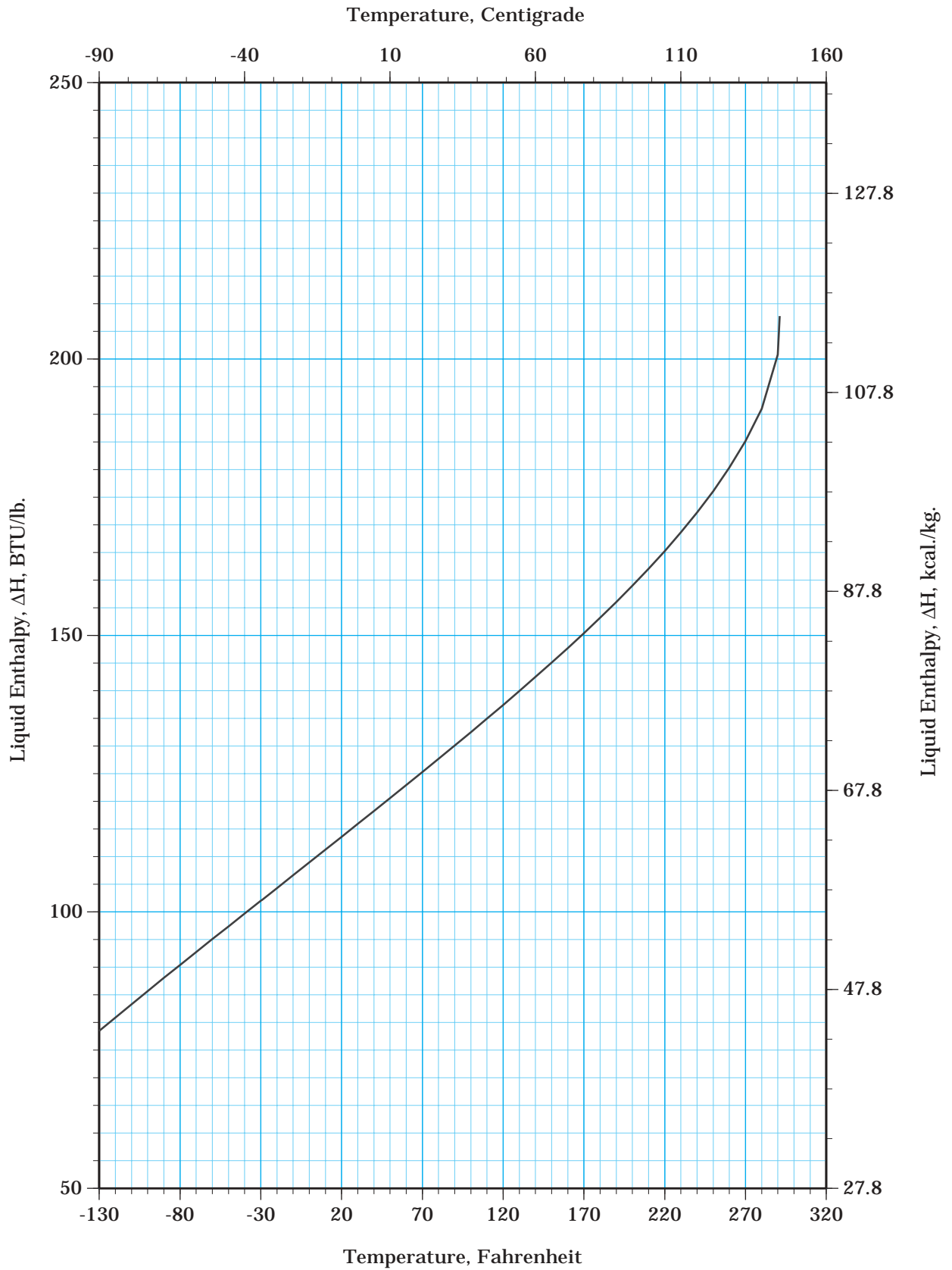

Bibliography

Kapoor, R.N.; Martin, J.J.
"Thermodynamic Properties of Chlorine"
Engineering Research Institute,
University of Michigan, Ann Arbor,
Michigan (1957).

Kirkbride, F.W.
in Mellow, J.W.: "Inorganic and
Theoretical Chemistry," Vol. II,
Suppl. I, Sect. XIII.
John Wiley & Sons Inc., New York
(1956).

Laubusch, E.J.
in "Chlorine, Its Manufacture, Prop-
erties and Uses," Ch. 3 (Ed.:
Sconce, J.S.)
ACS Monograph Series No. 154
Reinhold Publishing Corp., New
York (1962).

McBride, B.J.; Heibel, S.; Ehlers,
J.G.; Gordon, S.
"Thermodynamic Properties to
6000°K for 210 Substances Invol-
ving the First 18 Elements"
NASA SP-3001. Lewis Research
Center, Cleveland, Ohio (1963).

McGlashan, M.L.
"IUPAC Manual of Symbols and
Terminology for Physicochemical
Quantities and Units"
Pure Appl. Chem 21, 1 (1970).

Mussini, T.; Faita, G.
in "Encyclopedia of Electrochem-
istry of the Elements,"
Vol. 1, Ch. 1 (Ed.: Bard, A.J.)
Marcel Dekker, Inc., New York
(1973).

Setty, H.S.N.; Smith, J.D.; Yaws,
C.L.
Chem. Eng., 81 (12) 70 (1974).

Stull, D.R.; Prophet, H.
"JANAF Thermochemical Tables"
2nd Ed.
NSRDS – NBS37
National Bureau of Standards,
Washington, D.C., (1971).

Svehla, R.A.
"Estimated Viscosities and Thermal
Conductivities of Gases at High
Temperatures"
NASA Technical Report R-132
Lewis Research Center, Cleveland,
Ohio (1962).

Ziegler, L.
Chem. Ing. Tech., 22, 229 (1950).